

35 110

## GROHSAFE™ 3.0

### PRESSURE BALANCE ROUGH-IN VALVE

Pure Freude  
an Wasser



#### STANDARD SPECIFICATION:

- 1/2" Universal inlets/outlets
- Includes plug for 3-port installation
- Flush plug included
- Made of DZR Brass
- Service stops
- Can be tested using flush plug with air (200psi) or water (300psi).
- Cartridge ships with the trim

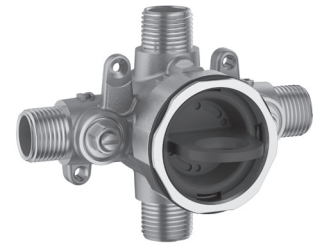

#### PRODUCT FEATURES:



#### CERTIFICATIONS:

- Massachusetts Plumbing Board Approved
- ASSE 1016
- CSA B125.1
- CSA B125.16
- ASME A112.18.1
- ASME A112.1016

#### AVAILABLE FINISHES:

**35110000** No Finish

NOTE: Install this product according to the installation guide. ADA, CSA compliant when installed to the specific requirements of these regulations.

We reserve the right to make revisions without notice to product specifications. 01-04-2022

**US**  
Tel: 1.630.582.7711 Fax: 1.630.582.7722  
For the most current Specification Sheet,  
go to [www.grohe.us](http://www.grohe.us).

**Canada**  
Tel: 1.888.644.7643 Fax: 1.905.366.2071  
For the most current Specification Sheet,  
go to [www.grohe.ca](http://www.grohe.ca).

PART OF **LIXIL**

35 110

# GROHSAFE™ 3.0

## PRESSURE BALANCE ROUGH-IN VALVE

Pure Freude  
an Wasser



### TECHNICAL DATA:

Product Height	3-5/8 in
Product Length	2-3/4 in
Product Width	4-7/8 in

**35 110 000**

**INLETS**  
1/2" NOM.  
COPPER SWEAT  
OR 1/2" NPT

**OUTLETS**  
1/2" NOM.  
COPPER SWEAT  
OR 1/2" NPT

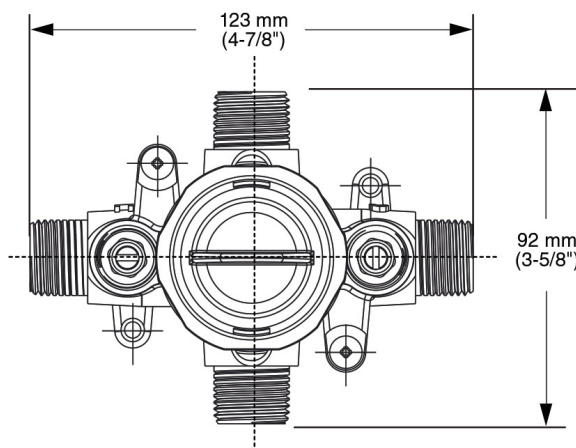

### SIDE VIEW

