

INDEPENDENCE

Residential

- Steam Boiler
- Cast Iron
- Chimney Vent
- Gas Fired

Manual Contents

Page

1. Pre-Installation	7
2. Knocked-Down Boiler Assembly	10
3. Semi-Pak Boiler Assembly	14
4. Packaged Boiler Assembly	16
5. Piping and Trim	17
6. Gas Piping	20
7. Venting	22
8. Electrical	25
9. System Start-Up	33
10. Service Instructions	42
11. Service Parts	48



TO THE INSTALLER:

Affix these instructions adjacent to boiler.

TO THE CONSUMER:

Retain these instructions for future reference.



Intertek
9700609

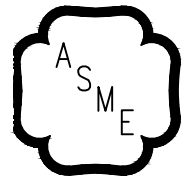

H

For service or repairs to boiler, call your heating contractor. When seeking information on boiler, provide Boiler Model Number and Serial Number as shown on Rating Label.

WARNING

Improper installation, adjustment, alteration, service or maintenance can cause property damage, injury, or loss of life. For assistance or additional information, consult a qualified installer, service agency or the gas supplier. This boiler requires a special venting system. Read these instructions carefully before installing.

The City of New York requires a Licensed Master Plumber supervise the installation of this product.

The Massachusetts Board of Plumbers and Gas Fitters has approved the Independence® Series boiler. See the Massachusetts Board of Plumbers and Gas Fitters website, http://license.reg.state.ma.us/pubLic/pl_products/pb_pre_form.asp for the latest Approval Code or ask your local Sales Representative.

The Commonwealth of Massachusetts requires this product to be installed by a Licensed Plumber or Gas Fitter.

The following terms are used throughout this manual to bring attention to the presence of hazards of various risk levels, or to important information concerning product life.

 DANGER

Indicates a hazardous situation that, if not avoided, will result in death or serious injury.

 CAUTION

Indicates a hazardous situation that, if not avoided, could result in minor or moderate injury.

 WARNING

Indicates a hazardous situation that, if not avoided, could result in death or serious injury.

NOTICE: Indicates special instructions on installation, operation, or service which are important but not related to personal injury hazards.

 CAUTION

If, during normal operation, it is necessary to add water to this boiler more frequently than once a month, consult a qualified service technician to check your system for leaks. A leaky system will increase the volume of make-up water supplied to the boiler which can significantly shorten the life of the boiler. Entrained in make-up water are dissolved minerals and oxygen. When the fresh, cool make-up water is heated in the boiler the minerals fall out as sediment and the oxygen escapes as a gas. Both can result in reduced boiler life. The accumulation of sediment can eventually isolate the water from contacting the cast iron. When this happens the cast iron in that area gets extremely hot and may eventually crack. The presence of free oxygen in the boiler creates a corrosive atmosphere which, if the concentration becomes high enough, can corrode the cast iron through from the inside. Since neither of these failure types are a result of a casting defect the warranty does not apply. Clearly, it is in everyone's best interest to prevent this type of failure. The maintenance of system integrity is the best method to achieve this.

NOTICE: This boiler has a limited warranty, a copy of which is included with this boiler. It is the responsibility of the installing contractor to see that all controls are correctly installed and are operating properly when the installation is complete.

- Surface rust on cast iron sections may be attributed to the manufacturing process as well as condensation during storage. Surface rust is normal and does not affect the performance or longevity of a boiler.

⚠ CAUTION

Probe type low water cutoff devices require annual inspection and maintenance! Although these devices are solid state in their operation, the probe is exposed to possible contamination in the boiler water and subject to fouling. Refer to Low Water Cutoff Service Instructions for complete, step-by-step inspection and cleaning instructions.

⚠ WARNING

- This boiler requires regular maintenance and service to operate safely. Follow the instructions contained in this manual.
- Improper installation, adjustment, alteration, service or maintenance can cause property damage, personal injury or loss of life. Read and understand the entire manual before attempting installation, start-up operation, or service. Installation and service must be performed only by an experienced, skilled, and knowledgeable installer or service agency.
- This boiler must be properly vented.
- This boiler needs fresh air for safe operation and must be installed so there are provisions for adequate combustion and ventilation air.
- The interior of the venting system must be inspected and cleaned before the start of the heating season and should be inspected periodically throughout the heating season for any obstructions. A clean and unobstructed venting system is necessary to allow noxious fumes that could cause injury or loss of life to vent safely and will contribute toward maintaining the boiler's efficiency.
- Installation is not complete unless a safety valve is installed. See the Piping and Trim Section of this manual for details.
- This boiler is supplied with safety devices which may cause the boiler to shut down and not re-start without service. If damage due to frozen pipes is a possibility, the heating system should not be left unattended in cold weather; or appropriate safeguards and alarms should be installed on the heating system to prevent damage if the boiler is inoperative.
- This boiler contains very hot water or steam under high pressure. Do not unscrew any pipe fittings nor attempt to disconnect any components of this boiler without positively assuring the water is cool and has no pressure. Always wear protective clothing and equipment when installing, starting up or servicing this boiler to prevent scald injuries. Do not rely on the pressure and temperature gauges to determine the pressure and temperature of the boiler. This boiler contains components which become very hot when the boiler is operating. Do not touch any components unless they are cool.
- Boiler materials of construction, products of combustion and the fuel contain alumina, silica, heavy metals, carbon monoxide, nitrogen oxides, aldehydes and/or other toxic or harmful substances which can cause death or serious injury and which are known to the state of California to cause cancer, birth defects and other reproductive harm. Always use proper safety clothing, respirators and equipment when servicing or working nearby the boiler.
- Failure to follow all instructions in the proper order can cause personal injury or death. Read all instructions, including all those contained in component manufacturers manuals which are provided with the boiler before installing, starting up, operating, maintaining or servicing.
- Keep boiler area clear and free from combustible materials, gasoline and other flammable vapors or liquids.
- All cover plates, enclosures and guards must be in place at all times.

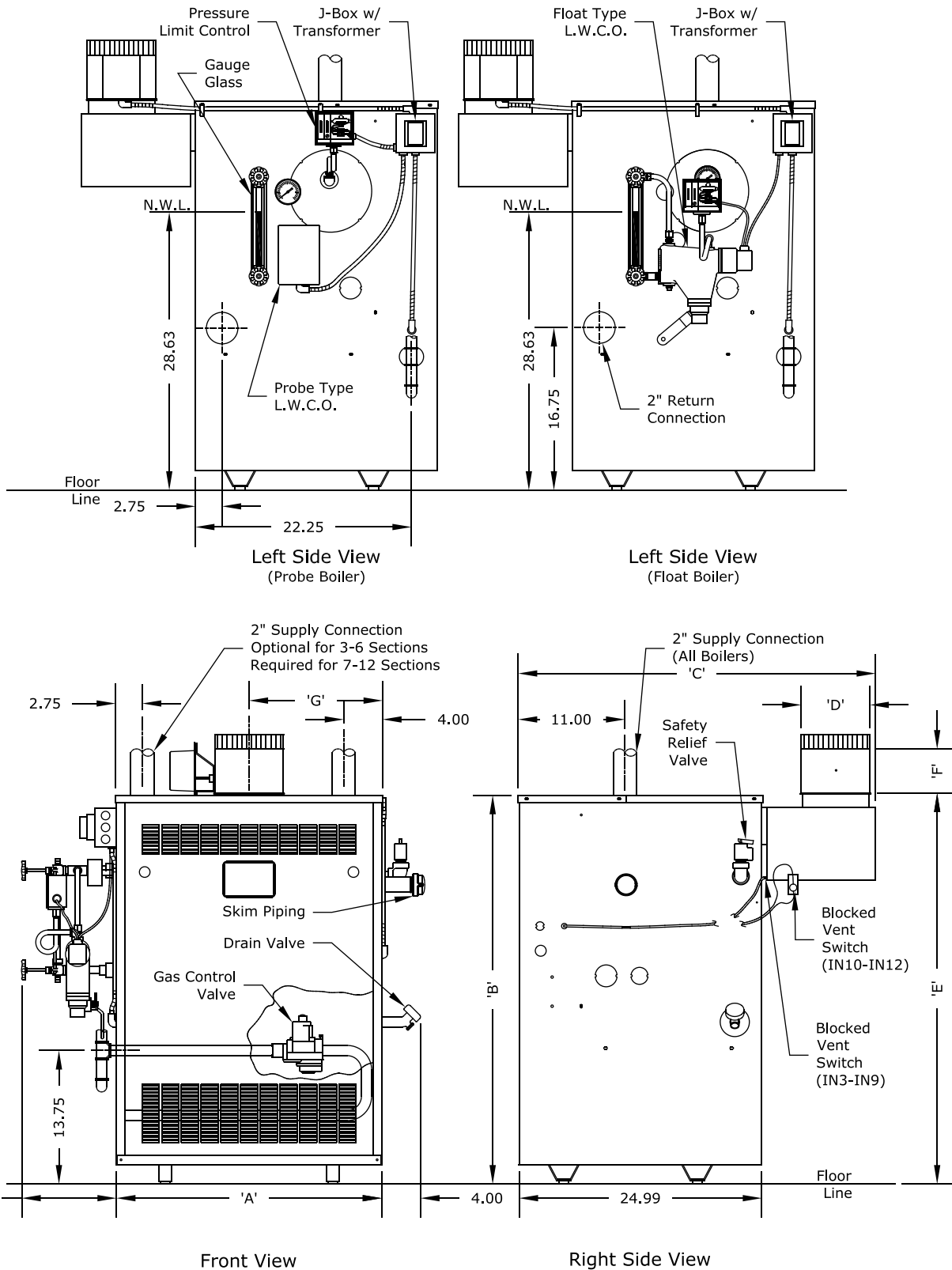

Figure 1: Dimensional Drawing

Table 1: Dimensional Data

Boiler Model	Approx. Shipping Weight Lbs.	Dimensions (in inches)							Recommended Min. Round Chimney Size (Diameter x Height) (1)	Gas Conn. (NPT)	Water Volume (Gal.)			
		'A'	'B'	'C'	'D'	'E'	'F'	'G'			Steam Boiler	(3)		
IN3I	350	14-1/2	40	33-3/4	4	40-1/4	4-3/4	7-1/4	4" x 15 ft.	1/2"	5.1	3.9		
IN4I	420	17-3/4		34-3/4	5			8-7/8	5" x 15 ft.		6.5	5.0		
IN5I	485	21		35-3/4	6			5-1/4	10-1/2		6" x 15 ft.	7.9	6.1	
IN6I	555	24-1/4		36-3/4	7		7-1/2	12-1/8	7" x 15 ft.		3/4"	9.3	7.2	
IN7I	620	27-1/2		37-3/4	8			13-3/4				10.7	8.3	
IN8I	690	30-3/4		8	15-3/8			12.1				9.4		
IN9I	760	34		45	38-3/4		9	45-1/2	7-1/2	17	8" x 15 ft.	3/4" (2)	13.5	10.5
IN10	815	37-1/4								18-5/8			14.9	11.6
IN11	885	40-1/2								20-1/4			16.3	12.7
IN12	955	43-3/4		45	38-3/4		9	45-1/2	7-1/2	21-7/8	9" x 15 ft.	1"	17.7	13.8

(1) 15' chimney height is from bottom of Draft Hood opening to top of Chimney.

(2) Gas connection size on IN10-IN11 Continuous Ignition (Standing Pilot) is 1 NPT.

(3) Steam boiler's "steamable water volume": water volume from NWL (normal water level) to low water cutoff level.

Heating Surface: 4.35 sq. ft. per flueway (steam); 5.72 sq. ft. per flueway (water)

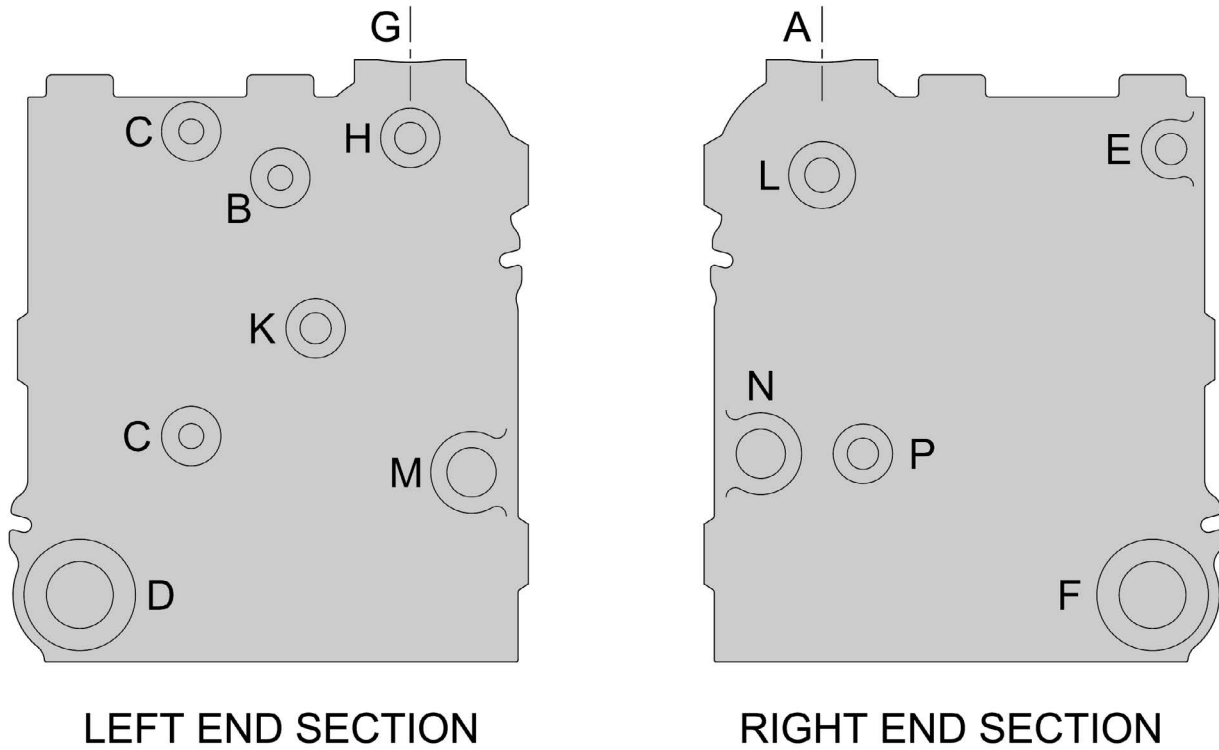

Figure 2: Section Tappings

Table 2: Trim and Control Installation in Section Tappings

Tapping	Size (NPT)	Boiler with Probe L.W.C.O.	Boiler with Float L.W.C.O.
A	2	Supply	Supply
B	1/2	Bush to 1/4 & Pressure Gauge	Plug
C	1/2	Gauge Glass	Nipple, 1/2 Union Gauge, L.W.C.O., Street Elbow, Syphon & Limit
D	2	Return	Return
E	3/4	3" Nipple, Street Elbow & Safety Valve	3" Nipple, Street Elbow & Safety Valve
F	2	Contractor Installed Bush to 3/4, Drain Valve and/or Optional Return	Contractor Installed Bush to 3/4, Drain Valve and/or Optional Return
G	2	Optional Supply (IN31-6) Required Supply (IN71-12)	Optional Supply (IN31-6) Required Supply (IN71-12)
H	3/4	Bush to 1/4 & Syphon Limit	Bush to 1/4 & Pressure Gauge
J	3/4	Not Applicable	Not Applicable
K	3/4	Low Water Cutoff	Plug
L	1 1/4	6" Nipple & Cap	6" Nipple & Cap
M	1 1/4	Factory Plugged Alliance SL™ Return	Factory Plugged Alliance SL™ Return
N	1 1/4	Factory Plugged Alliance SL™ Supply	Factory Plugged Alliance SL™ Supply
P	3/4	Factory Plugged Alliance SL™ Limit	Factory Plugged Alliance SL™ Limit

1 Pre-Installation

⚠ WARNING

If you do not follow these instructions exactly, a fire or explosion may result causing property damage or personal injury.

⚠ DANGER

Do not install boiler where gasoline or other flammable vapors or liquids, or sources of hydrocarbons (i.e. bleaches, cleaners, chemicals, sprays, paint removers, fabric softeners, etc.) are used or stored.

NOTICE: Due to the low water content of the boiler, mis-sizing of the boiler with regard to the heating system load will result in excessive boiler cycling and accelerated component failure. U.S. Boiler Company DOES NOT warrant failures caused by mis-sized boiler applications. DO NOT oversize the boiler to the system.

- A. Inspect shipment carefully for any signs of damage. All equipment is carefully manufactured, inspected and packed. Our responsibility ceases upon delivery of boiler to carrier in good condition. Any claim for damage or shortage in shipment must be filed immediately against carrier by consignee. No claims for variances or shortages will be allowed by Boiler Manufacturer, unless presented within sixty (60) days after receipt of equipment.
- B. The installation must conform to the requirements of the authority having jurisdiction. In the absence of such requirements, installation must conform to the *National Fuel Gas Code*, ANSI Z223.1/NFPA 54, and/or *Natural Gas and Propane Installation Code*, CAN/CSA B149.1.
Where required by the authority having jurisdiction, the installation must conform to the *Standard for Controls and Safety Devices for Automatically Fired Boilers*, ANSI/ASME No. CSD-1.
- C. Boiler is design certified for installation on combustible flooring. Boiler must not be installed on carpeting.
- D. Provide clearance between boiler jacket and combustible material in accordance with local fire ordinance. See Figure 3 for minimum listed clearance to combustible material.
Recommended service clearance is 24 inches (61.0 cm) from left side, right side, and front. Additional clearance may be required on left side if optional tankless heater is installed. Service clearances may be reduced to minimum clearances to combustible materials.

Provide 1/2" (1.3 cm) between combustible construction and steam/hot water piping.

- E. Install boiler on level floor as close to chimney as possible. For basement installation provide a solid base, such as concrete, steel or masonry if floor is not level or if water may be encountered on floor around boiler.
- F. Protect gas ignition system components from water (dripping, spraying, rain, etc.) during boiler operation and service (circulator replacement, control replacement, etc.).
- G. Provide combustion and ventilation air in accordance with section "Air for Combustion and Ventilation," of the *National Fuel Gas Code*, ANSI Z223.1/NFPA 54, or Clause 8.2, 8.3, or 8.4 of *Natural Gas and Propane Installation Code*, CAN/CSA B149.1, or applicable provisions of local building codes.

⚠ WARNING

Adequate combustion and ventilation air must be provided to assure proper combustion.

The following guideline is based on the National Fuel Gas Code, ANSI Z223.1/NFPA 54.

1. General requirements
 - a. Air for combustion, ventilation and dilution of flue gases shall be obtained using indoor combustion air (paragraph 2 below), outdoor combustion air (3), combination of indoor and outdoor combustion air (4), engineered installations (5), or mechanical combustion air supply (6).
 - b. Boiler and other appliances shall be located to prevent interference with proper circulation of combustion, ventilation and dilution air.
 - c. Provide make-up air where exhaust fans, clothes dryers, and kitchen ventilation systems interfere with operation of boiler and other appliances.
2. Indoor combustion air. Total required volume of indoor combustion air is the sum of required volume calculated for all appliances located within space. Rooms communicating directly with space in which appliances installed through openings not furnished with doors, and through combustion air openings sized and located per paragraph 2c, are considered part of required volume.

1 Pre-Installation *(continued)*

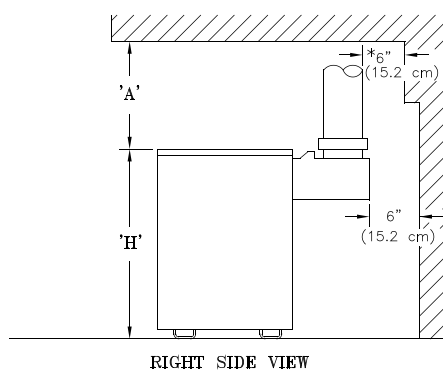
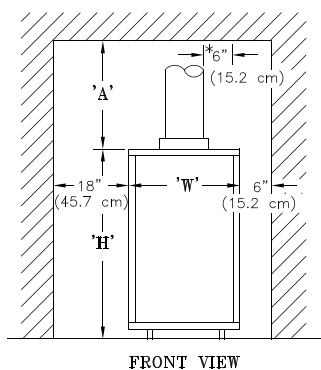
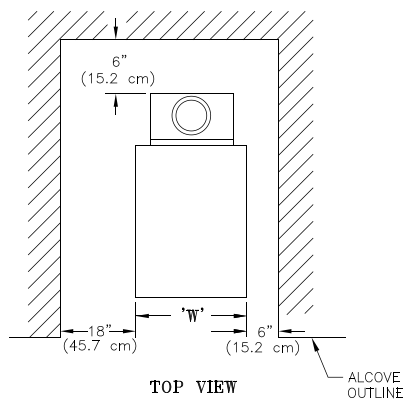

DIMENSION		'A'	'H'	'W'
BOILER MODELS	IN3	17" (43.2 cm)	40"	14½"
	IN4	17" (43.2 cm)	40"	17¾"
	IN5	17" (43.2 cm)	40"	21"
	IN6	17" (43.2 cm)	40"	24¼"
	IN7	17" (43.2 cm)	40"	27½"
	IN8	17" (43.2 cm)	40"	30¾"
	IN9	17" (43.2 cm)	40"	34"
	IN10	12" (30.5 cm)	45"	37¼"
	IN11	12" (30.5 cm)	45"	40½"
	IN12	12" (30.5 cm)	45"	43¾"

* MINIMUM RADIAL CLEARANCE AROUND FLUE.

Figure 3: Clearance to Combustible Materials

- a. Standard method. Minimum required volume is 50 ft³ per Mbh.
- b. Known air infiltration rate. Must be used where air infiltration rate is less than 0.40 air changes per hour (ACH). Do not use an infiltration rate greater than 0.60 ACH.

$$\text{Volume} \geq \frac{(21 \text{ ft}^3 \times I_{\text{other}}) + (15 \text{ ft}^3 \times I_{\text{fan}})}{\text{ACH}}$$

where: I_{other} = total input rate of all appliances other than fan-assisted (Mbh)
 I_{fan} = total input of fan-assisted appliances (Mbh)
 ACH = air changes per hour
 Mbh = 1000 Btu per hour

- c. Size and locate openings connecting indoor spaces
 - i. Combining spaces on same story. Locate on opening commencing within 12 in. of top of enclosure. Locate second opening commencing within 12 in. of bottom of enclosure. Size each opening for minimum free area of 1 in² per Mbh, but not less than 100 in². Minimum dimension of air openings not less than 3 in.

- ii. Combining spaces in different stories. Spaces on different stories are considered as communicating when connected by one or more openings in doors or floors having a total minimum free area of 2 in² per Mbh.

3. Outdoor combustion air. Provide opening(s) to outdoors per a or b below. Minimum dimension of air openings not less than 3 in.

- a. Two permanent openings method. Locate one permanent opening commencing within 12 in. of top of enclosure. Locate second permanent opening commencing within 12 in. of bottom of enclosure.
 - i. Direct communication or through vertical ducts. Size each opening for minimum free area of 1 in² per 4 Mbh of total input rating of all appliances in enclosure.
 - ii. Through horizontal ducts. Size each opening for minimum free area of 1 in² per 2 Mbh.
- b. One permanent opening method. Locate one permanent opening commencing within 12 in. of top of enclosure.

1 Pre-Installation *(continued)*

4. Combination indoor and outdoor combustion air.
 - a. Indoor openings, when used, must comply with paragraph 2c above.
 - b. Outdoor opening(s) location must comply with paragraph 3 above.
 - c. Calculate outdoor opening size per the following:
 - i. Determine ratio of interior spaces: available volume of all communicating spaces divided by required volume.
 - ii. Determine outdoor size reduction factor: 1 minus ratio of interior spaces
 - iii. Minimum size of outdoor opening is full size of outdoor air opening(s) per paragraph 3 multiplied by outdoor size reduction factor.
 - iv. Minimum dimension of air openings not less than 3 in.
 5. Engineered installations. Provide adequate supply of combustion, ventilation, and dilution air using engineered methods as approved by local authority having jurisdiction.
 6. Mechanical combustion air supply. Provide outdoor air at minimum rate of 0.35 cfm per Mbh for all appliances located within space.
 - a. Provide additional air where exhaust fans installed to replace exhausted air.
 - b. Interlock each appliance to mechanical combustion air supply to prevent main burner operation when mechanical combustion air supply system not in operation.
 - c. Provide specified combustion air plus ventilation air when combustion air provided by building's mechanical ventilation system.
 7. Ventilation Duct Louvers and Grilles. Equip outside openings with louvers to prevent entrance of rain and snow, and screens to prevent entrance of insects and rodents. Louvers and grilles must be fixed in open position or interlocked with equipment to open automatically before burner operation and to shut down burner operation if louvers close during burner operation. Screens must not be smaller than ¼ inch mesh.

Consider the blocking effect of louvers, grilles and screens when calculating the opening size to provide the required free area. If free area of louver or grille is not known, assume wood louvers have 25 percent free area and metal louvers and grilles have 75 percent free area.
 8. Combustion air ducts shall comply with following:
 - a. Constructed of galvanized steel or material having equivalent corrosion resistance, strength, and rigidity. Exception for dwelling units. Unobstructed stud and joist spaces are not prohibited from conveying combustion air provided not more than one fire block is removed.
 - b. Terminate in unobstructed space, allowing free movement of combustion air to appliance(s).
 - c. Serve single space.
 - d. Two permanent openings method. Single duct cannot serve both upper and lower openings. Maintain separation between ducts serving upper and lower openings to source of combustion air.
 3. Do not screen where terminating in attic spaces.
 - f. Horizontal ducts cannot slope downward toward combustion air source.
 - g. Do not use space surrounding chimney liner, gas vent, special gas vent, or plastic piping installed within masonry, metal, or factory built chimney.
 - h. Combustion air intake located on building exterior shall have lowest side of intake located at least 12 in. vertically from adjoining finish ground level.
- H.** Do not install boiler where gasoline or other flammable vapors or liquids, or sources of hydrocarbons (i.e. bleaches, cleaners, chemicals, sprays, paint removers, fabric softeners, etc.) are used or stored.

2 Knocked-Down Boiler Assembly

WARNING

Installation of this boiler should be undertaken only by trained and skilled personnel from a qualified service agency.

A. Install Base-Burner-Manifold Assembly

1. Base-Burner-Manifold is shipped assembled from factory (Gas Valve and Pilot/Burner Assembly is shipped in the "Gas Controls Carton").
2. Unpack base assembly and place in location where boiler is to be installed (Refer to Section I: Pre-Installation).

B. Install assembled cast iron sections on base assembly:

1. Install (4) 5/16" x 1/4" self-tapping screws through (4) holes in upper base flange with screw heads on underside of flange. Note: Screws are located in fiber gasket parts bag.
2. Install ceramic fiber gasket. See Figure 4.

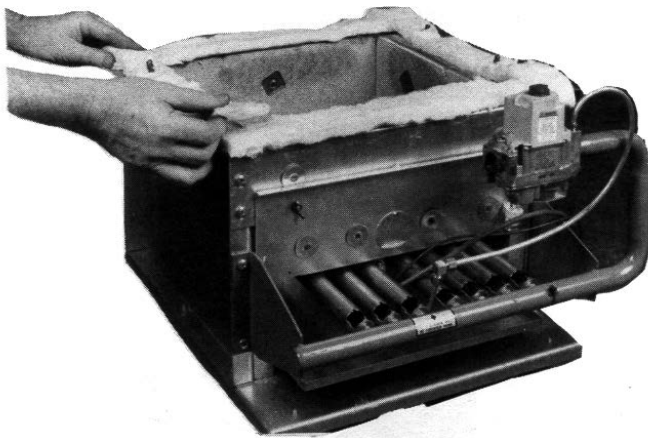

Figure 4: Base Gasket Installation

3. Position boiler above base with lugs cast in boiler sections centered over screws protruding from top of base. Lower boiler onto base taking care not to disturb ceramic fiber gasket. Secure with 5/16" locknuts and washers provided. See Figure 5.
4. Loosen nuts on tie rods until only finger tight.
5. If Steam boiler less tankless heater, proceed to Paragraph C.

Note: If tankless heater is not installed, heater opening cover plate must remain in place.

C. Test boiler for leaks before connecting to system and installing controls, trim and jacket.

1. Attach pressure gauge (capable of indicating 30 psi) on boiler.



Figure 5: Section Assembly Attachment

2. Attach fill valve and piping to return tapping and purge valve to supply tapping. See Figure 6.
3. Install plugs in remaining tappings.
4. Fill boiler completely with water by venting air through purge valve. Close purge valve and apply water pressure of at least 10 psi but not exceeding 30 psi gauge pressure.
5. Examine boiler carefully inside and outside for leaks or damage due to shipment or handling.

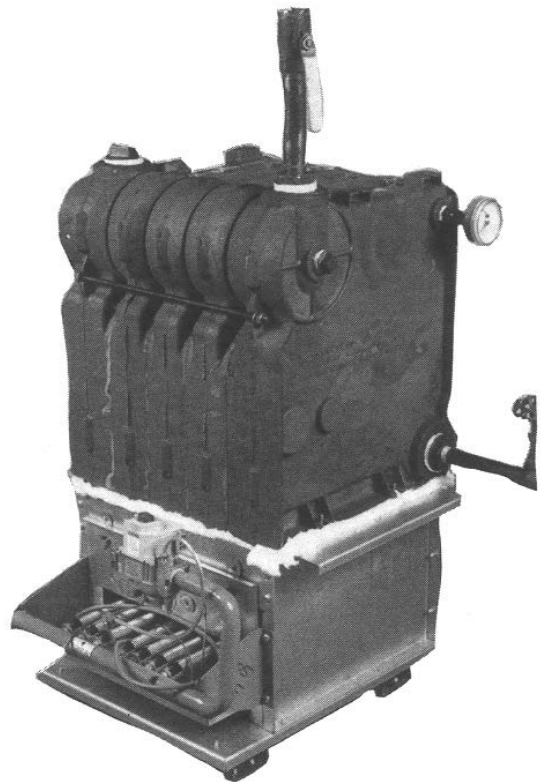

Figure 6: Hydrostatic Pressure Test

2 Knocked-Down Boiler Assembly *(continued)*

D. Install Canopy.

1. Install ½" thick x 1" wide ceramic fiber gasket. See Figure 7.

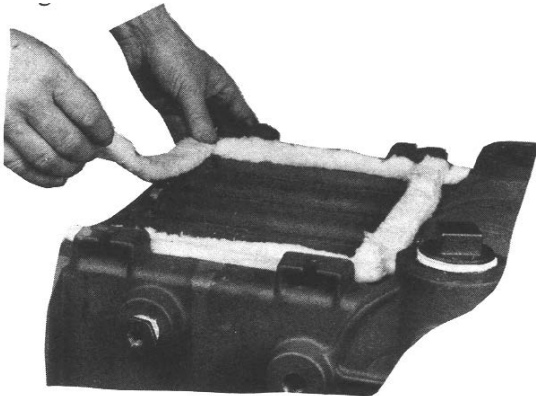

Figure 7: Canopy Gasket Installation

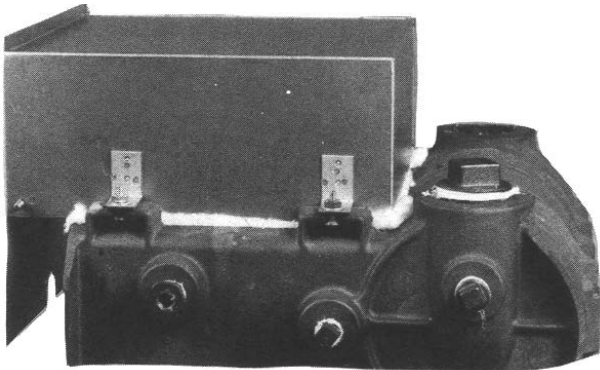

Figure 8: Canopy Installation

2. Position canopy on ceramic fiber gasket. See Figure 8.
3. Attach canopy using ¼" carriage bolts, nuts, and washers provided.

E. Inspect joints between sections. They were factory sealed. If there are any openings due to shipment or handling, reseal with boiler putty.

F. Install Jacket.

1. Models IN7I-IN12: remove 3 inch diameter knockouts in jacket top panels.
2. Raise rear panel under rear flange of canopy and rest on floor. Position rear panel and secure to jacket side panels with sheet metal screws. For Models IN10-IN12, secure jacket upper rear panels to side panels with sheet metal screws.
3. Secure both jacket side panels to base with sheet metal screws.
4. Position front tie bar and secure to jacket side panels with sheet metal screws.
5. Position vestibule panel and secure to side panels with sheet metal screws.
6. Attach Rating Label and Vent Damper Instruction Label at designated locations on vestibule panel.
7. Install top panels by placing over and around outside of side and rear panels. Seat fully and secure with sheet metal screws.

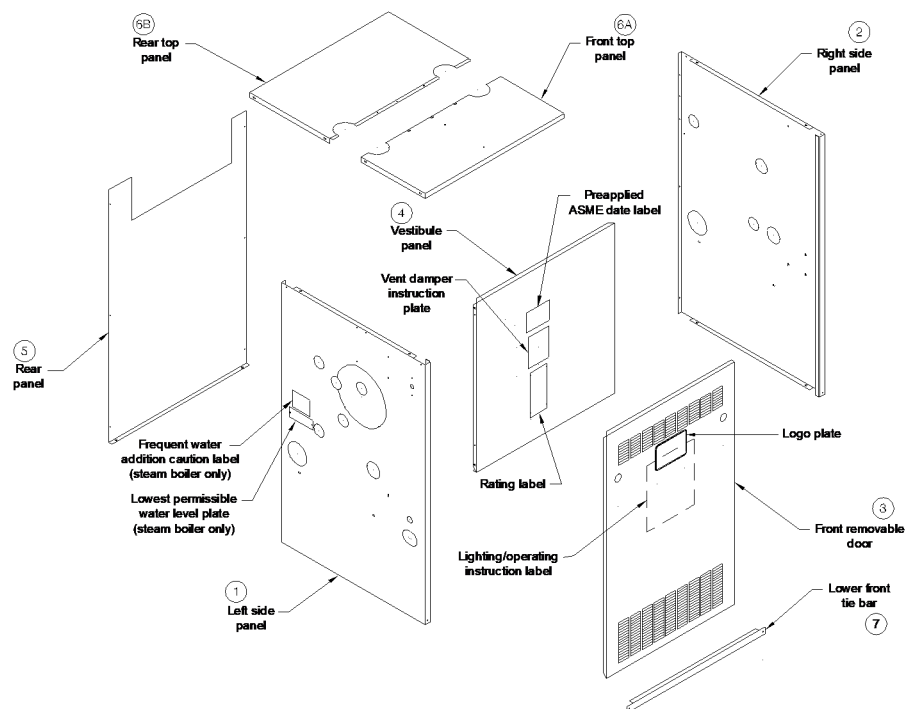

Figure 9: Jacket Assembly

2 Knocked-Down Boiler Assembly *(continued)*

8. Install black plastic rings into 1-3/32 inch diameter holes located below upper louvers of front removable door.
9. Install front removable door by engaging upper side edges of panel with side receiving flanges, sliding up and under top panel flange - seating front door fully - then sliding down to engage bottom flange behind lower front tie bar.

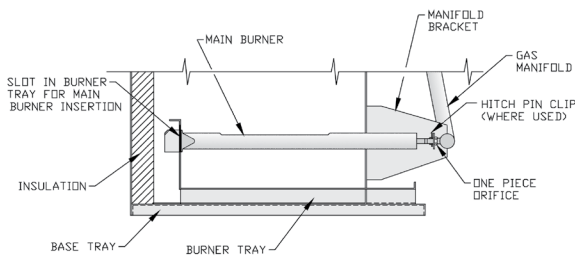

Figure 10: Combustion Chamber

G. Install Pilot/Burner Assembly (shipped in Gas Controls Carton). See Figure 10.

1. Remove jacket front removable door.
 - a. Remove burner access panel located above burners.
 - b. Install Pilot/Burner Assembly where noted on gas manifold.
 - i. Insert rear of burner in burner tray slot.
 - ii. Position burner over the orifice.
NOTE: The burner to the right may need to be lifted from the orifice to install pilot/burner assembly. Reinstall lifted burner over the orifice.
 - c. Reinstall burner access panel.

H. Install Gas Valve on main gas burner assembly (if not factory assembled). See Figure 11, 12 or 13.

1. Connect gas valve to manifold.
2. Connect pilot tubing from pilot burner to gas valve pilot tapping.
3. Continuous Ignition (standing pilot): connect thermocouple to gas valve.

I. Install Blocked Vent Switch with sheet metal screws.

1. Models IN31 - IN9I. Install on rear flange of canopy. See Figure 14.
2. Models IN10 - IN12. Install on right side of draft hood. See Figure 15. Reset switch must face away from draft hood relief opening.
3. Attach black 18-2 harness to Blocked Vent Switch terminals. Use end with two fully insulated disconnects.

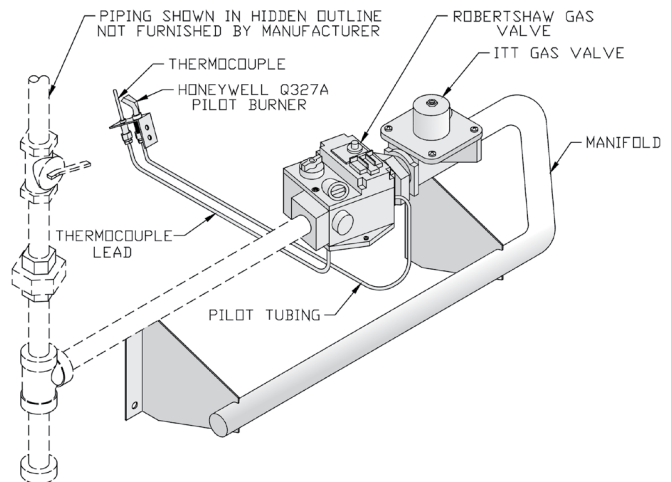

Figure 11: Pilot and Gas Piping, Continuous Ignition (Standing Pilot) (IN10 through IN12 Only)

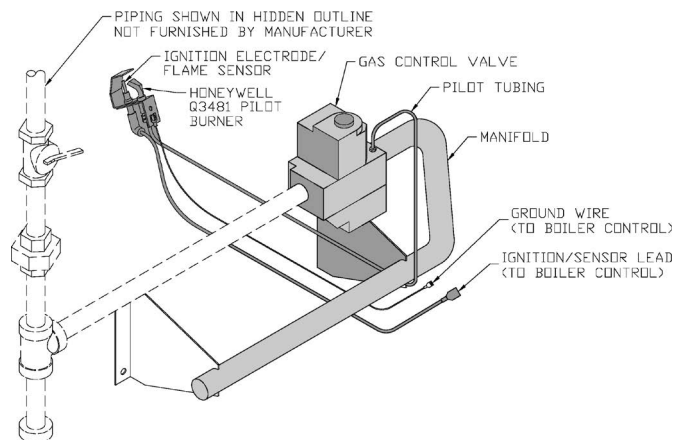

Figure 12: Pilot and Gas Piping, Intermittent Ignition (EI) (IN31 through IN11 Only)

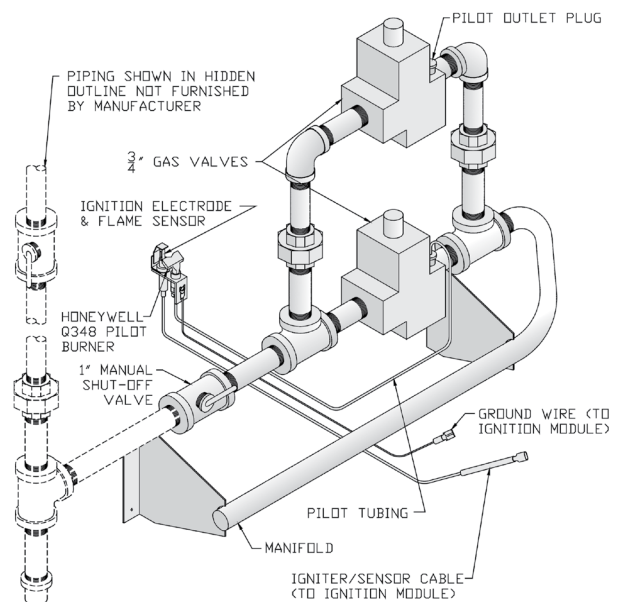

Figure 13: Pilot and Gas Piping, Intermittent Ignition (EI) (IN12 Only)

2 Knocked-Down Boiler Assembly *(continued)*

4. Secure harness to right side jacket panel with clamp.
5. Insert harness through $\frac{3}{4}$ inch hole in right side jacket panel. Secure with strain relief bushing.

J. Intermittent Ignition (EI): Install Ignition Module.

1. Mount ignition module mounting bracket to inside of right side panel using (2) #6 x $\frac{3}{4}$ " sheet metal screws provided.

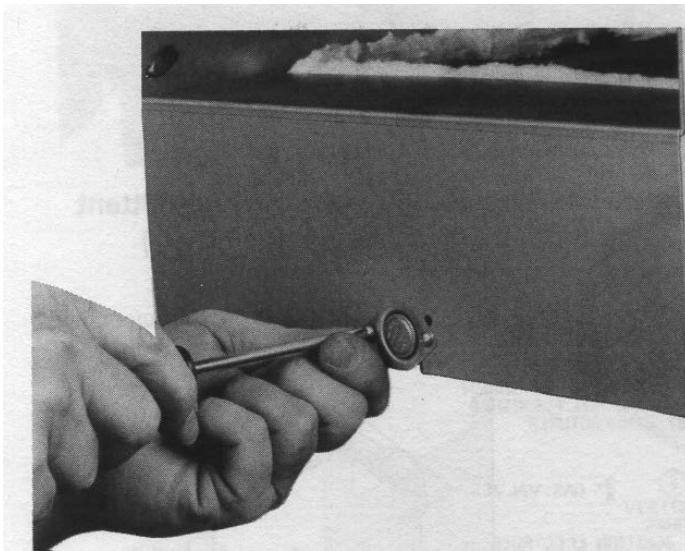

Figure 14: Blocked Vent Switch Installation, IN31 through IN91

2. Mount ignition module to bracket using (2) #8 x $\frac{1}{2}$ " sheet metal screws provided.
3. Install (3) wire harness from ignition module to gas valve as shown in wiring diagrams.

K. Continue to Section III: Semi-Pak Boiler Assembly, Paragraph C.

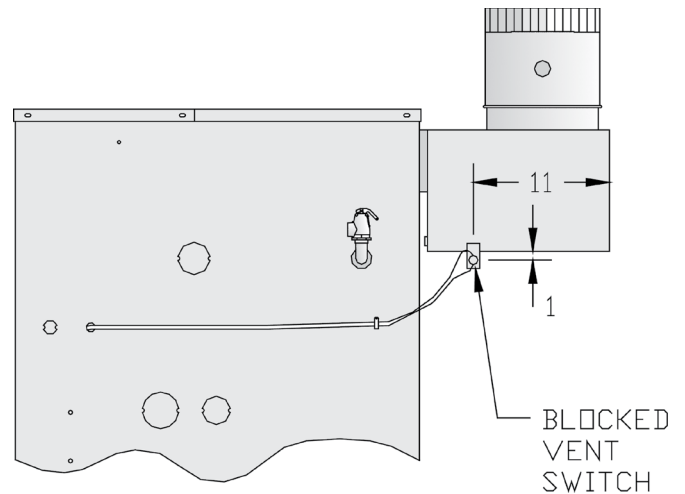

Figure 15: Blocked Vent Switch Installation, IN10 through IN12

3 Semi-Pak Boiler Assembly

⚠ WARNING

Installation of this boiler should be undertaken only by trained and skilled personnel from a qualified service agency.

A. Remove Crate

1. Remove all hold down screws and brackets.
2. Slide boiler to rear of skid and carefully remove from crate skid onto 2 inch thick piece of wood and then onto floor. Do not bump boiler jacket against floor.
3. Do not drop boiler at any time.

B. Move Boiler To Permanent Position. Refer to Section I: Pre-Installation.

C. Identify Trim and Controls

FIRST - Determine controls ordered with boiler and refer to appropriate section(s) following: There are two ordering methods for trim and controls:

1. EZ-Connect Carton includes trim, controls, wiring and wiring instructions for installation.
2. Separate Trim Carton and Control Carton. Only wiring requiring special connections is provided. For wiring requirements, refer to Section VIII: Electrical and appropriate wiring diagram.

D. Install Trim and Controls

Refer to appropriate paragraphs (following) for trim and controls to be installed.

1. Steam Boiler with Probe Low Water Cutoff

- a. Install pressure limit control into Tapping "H" with siphon, $\frac{3}{4}$ " x $\frac{1}{4}$ " hex bushing, $\frac{3}{4}$ " elbow and $\frac{3}{4}$ " x 3" nipple provided. See Figures 1 and 2. **DO NOT TWIST CONTROL.** Use wrench on hex fitting located at bottom of control. See Figure 16.
- b. The L404F pressure limit employs a snap action switch and does not require leveling. See Figure 16.
- c. Install pressure gauge into Tapping "B" ($\frac{1}{2}$ NPT bushed to $\frac{1}{4}$ NPT). See Figures 1 and 2. Tighten with wrench applied to square shank on back of gauge. **DO NOT APPLY PRESSURE ON GAUGE CASE** since this may destroy calibration of gauge.
- d. Install Low Water Cutoff Probe into Tapping "K" ($\frac{3}{4}$ NPT). **HANDLE PROBE WITH CARE.**
- e. Attach Low Water cutoff Control to Probe by following instructions packed with control.

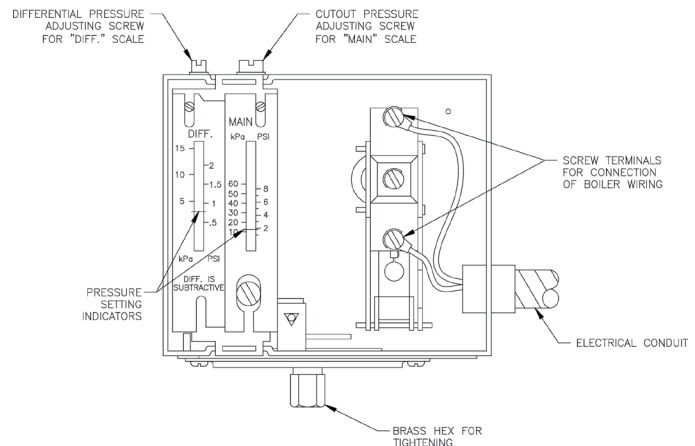

Figure 16: L404F Pressure Limit Control

- f. Install gauge glass fittings into Tappings "C" ($\frac{1}{2}$ NPT). See Figures 1 and 2. Lower fitting has small drain valve.
 - g. Install gauge glass and protective rods in fittings.
 - h. Attach "Lowest Permissible Water Level" Plate with sheet metal screws in location indicated in Figure 9.
 - i. Attach "Frequent Water Addition" Label above the "Lowest Permissible Water Level" Plate.
2. **Steam Boiler with McDonnell & Miller 67 Float Low Water Cutoff**
 - a. Install Low Water Cutoff, see instructions packed with control.
 - i. Screw brass nipples with union halves into Tappings "C" ($\frac{1}{2}$ NPT). See Figure 1 and 2.
 - ii. Attach Gauge Glass/Low Water Cutoff Assembly to union halves.
 - iii. Affix Blow-Down Card to Jacket Left Side Panel adjacent to low water cutoff.
 - iv. Provide blow down discharge piping.
 - b. Attach street elbow siphon and pressure limit control to low water cutoff. **DO NOT TWIST CONTROL.** Use wrench on hex fitting located at bottom of control.
 - c. The L404F pressure limit employs a snap action switch and does not require leveling. See Figure 16.
 - d. Install pressure gauge into Tapping "H" ($\frac{3}{4}$ NPT bushed to $\frac{1}{4}$ NPT). See Figures 1 and 2. Tighten with wrench applied to square shank on back of gauge. **DO NOT APPLY PRESSURE ON GAUGE CASE** since this may destroy calibration of gauge.

3 Semi-Pak Boiler Assembly *(continued)*

- e. Attach "Lowest Permissible Water Level" Plate with sheet metal screws in location indicated in Figure 9.
- f. Attach "Frequent Water Addition" Label above the "Lowest Permissible Water Level" Plate.

3. All Steam Boiler Controls Cartons

- a. Install Junction Box. See Figure 17A.
 - i. Remove center knockout in rear of Junction Box and insert black plastic snap bushing in hole.
 - ii. Install mounting bracket to rear of Junction Box with two (2) blunt sheet metal screws provided.
 - iii. Align center and mounting holes of Junction Box with upper front corner of jacket left side panel.
 - iv. Install Junction Box to jacket from inside vestibule area with two (2) blunt sheet metal screws provided.
- b. Mount transformer on Junction Box. For Canadian boiler provide strain relief by loosely securing Transformer to Junction Box with wire tie inserted through Transformer plate and a Junction Box mounting hole. See Figure 17B.
- c. Fork connector on yellow wire of gas valve harness must be removed and wire stripped before making wire connections. Refer to Section VIII for wiring.
- d. Steam Boilers only. Secure the R8222 Thermostat Isolation Relay to upper left corner of jacket vestibule panel with sheet metal screws provided. See Figure 18.

- E. Continue to Section IV. Packaged Boiler Assembly, Paragraph E.

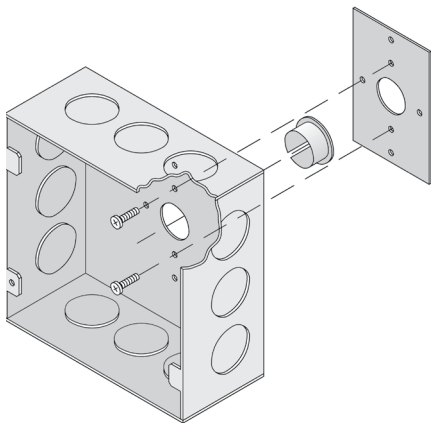

Figure 17A: Junction Box and Mounting Bracket Assembly

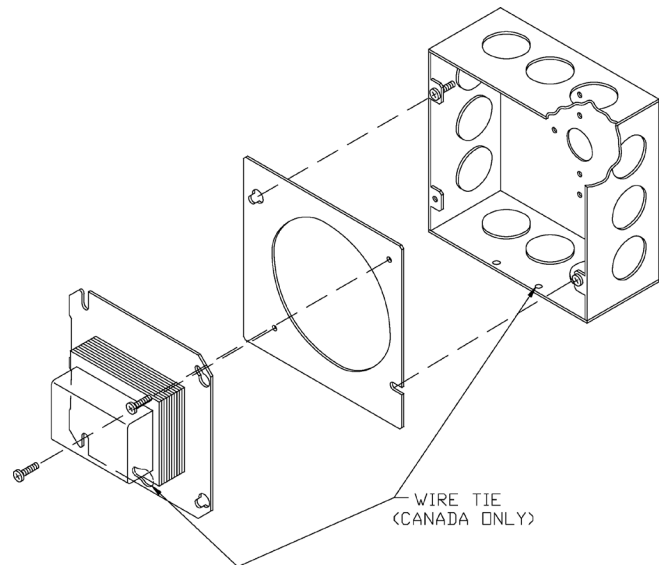

Figure 17B: Junction Box and Transformer Assembly

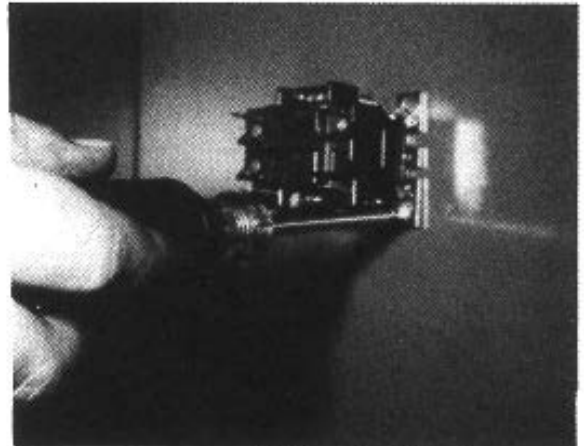

Figure 18: Thermostat Isolation Relay Attachment

4 Packaged Boiler Assembly

WARNING

Installation of this boiler should be undertaken only by trained and skilled personnel from a qualified service agency.

- A. Remove crate** and move boiler to permanent position as detailed in Section III: Semi-Pak Boiler Assembly.
- B. Remove Jacket Front Panel.** See Figure 35.
- C. Remove poly bag** from vestibule area.
- D. On Steam Boilers with probe low water cutoff** the L404 pressure limit/control has been packed in the vestibule area.
 1. Screw the pressure limit/control onto the syphon. **DO NOT TWIST CONTROL.** Use wrench on hex fitting at bottom of control. See Figure 16.
 2. Snap the electrical conduit from the adjacent junction box into the hole in the control.
 3. Open the control's clear cover and attach the two (2) wires in the conduit to the two (2) unused screw terminals.

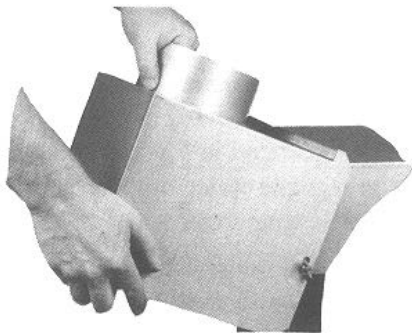

Figure 19: Draft Hood Attachment

E. Install Jacket Front Panel.

F. Install Draft Hood. Models IN3I through IN9I.

1. Locate and open "Drafthood Carton Assembly".
2. Position Draft Hood on Canopy Rear Flange. See Figure 19. Top canopy flange must fully engage "U"-shaped draft hood flange for proper installation and operation. Care must be taken to assure that draft hood is level.
3. Secure Rear Draft Hood to Canopy with wing nuts provided. See Figure 20.

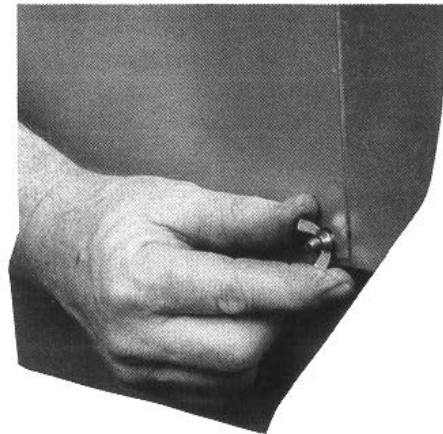

Figure 20: Securing Draft Hood to Canopy

WARNING

Do not alter boiler draft hood or place any obstruction or non-approved damper in the breeching or vent system. Flue gas spillage can occur. ETL/ETLC certification will become void.

5 Piping and Trim

⚠ WARNING

- Failure to properly pipe boiler may result in improper operation and damage to boiler or structure.
- Do not use softened water in steam boilers. Accelerated boiler corrosion will result. Tie in fresh water supply to the boiler upstream of a water softener.
- Oxygen contamination of boiler water will cause corrosion of iron and steel boiler components, and can lead to boiler failure. U.S. Boiler Company's Standard Warranty does not cover problems caused by oxygen contamination of boiler water or scale (lime) build-up caused by frequent addition of water.

- A.** Design and install boiler and system piping to prevent oxygen contamination of boiler water. Sources of oxygen contamination are system leaks requiring addition of makeup water, fittings, and oxygen permeable materials in distribution system. Eliminate oxygen contamination by repairing system leaks, repairing fittings, using nonpermeable materials in distribution system, and eliminating open tanks in system, or isolating boiler from system with heat exchanger.
- B.** Install Safety Valve in Tapping "E" ($\frac{3}{4}$ NPT). See Figure 21. Use $\frac{3}{4}$ NPT x 3" nipple and $\frac{3}{4}$ NPT elbow provided. Safety Valve must be installed with spindle in vertical position.

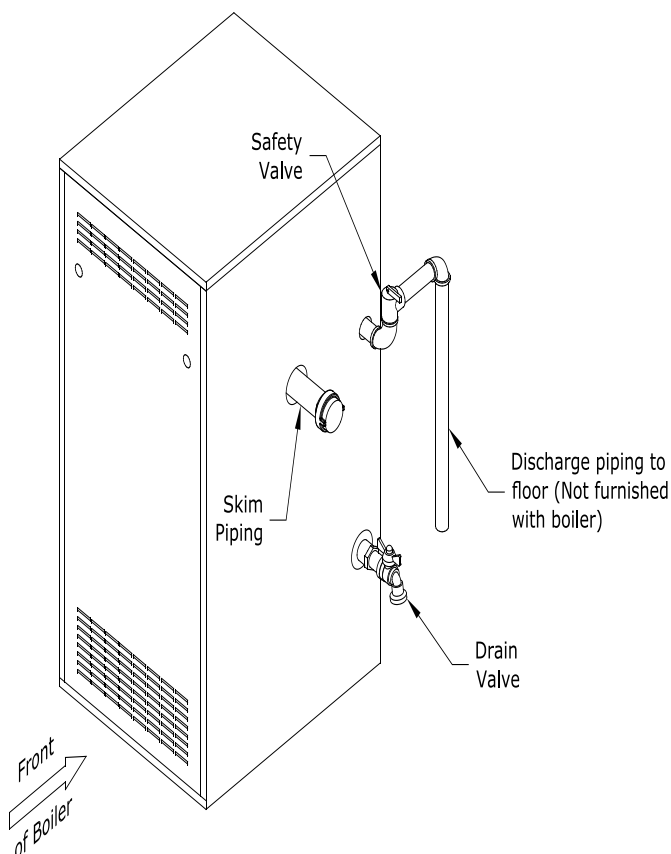

Figure 21: Trim Installation

⚠ WARNING

Safety valve discharge piping must be piped such that the potential of severe burns is eliminated. DO NOT pipe in any area where freezing could occur. DO NOT install any shut-off valves, plugs or caps. Consult Local Codes for proper discharge piping arrangement.

- C.** Install 2 NPT x $\frac{3}{4}$ NPT bushing provided in Tapping F. Install Drain Valve in Tapping "F" See Figure 21.
- D.** Install skim pipping in Tapping "L". Use 1 1/4 NPT x 6" nipple and cap provided. See Figure 21.
- E.** Connect supply and return piping to heating system. Maintain minimum $\frac{1}{2}$ inch clearance from combustible materials.
1. For STEAM HEATING see Figure 22. Consult I=B=R, "Residential Hydronic Heating Installation and Design Guide".
 2. If boiler is used in connection with refrigeration systems, boiler must be installed with chilled medium piped in parallel with heating boiler using appropriate valves to prevent the chilled medium from entering the boiler. See Figure 23. Also consult I=B=R, "Residential Hydronic Heating Installation and Design Guide".
 3. Boiler piping system of hot water boiler connected to heating coils located in air handling units where they may be exposed to refrigerated air circulation must be equipped with flow control valves or other automatic means to prevent gravity circulation of boiler water during cooling cycle.
 4. If a tankless heater coil is used, connect water lines to $\frac{3}{4}$ NPT tappings in coil plate.

5 Piping and Trim (continued)

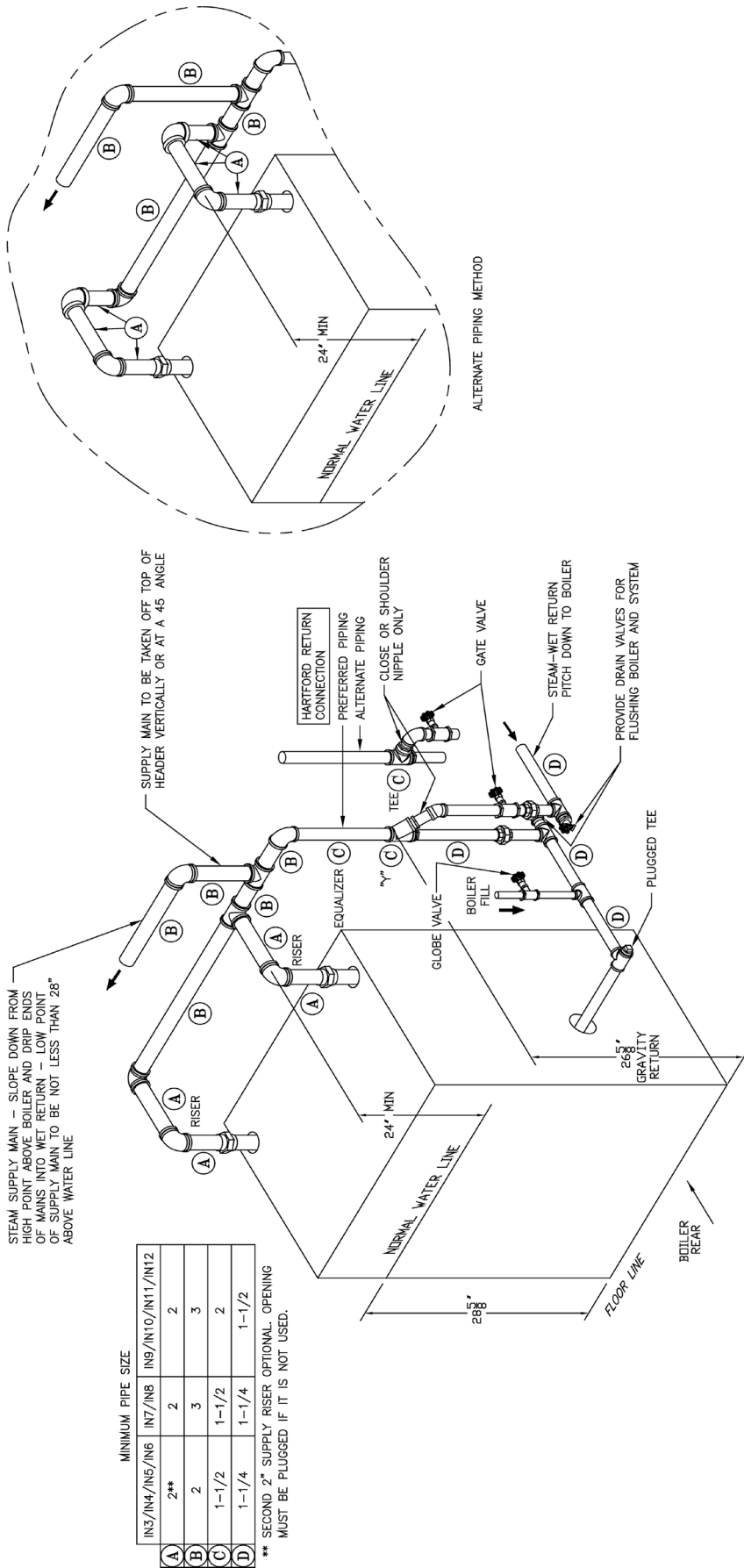

Figure 22: Steam Boiler Piping (Minimum)

NOTICE Failure to pipe boiler as specified in this manual may result in excessive system noise, water line fluctuations and water carry over.

5 Piping and Trim *(continued)*

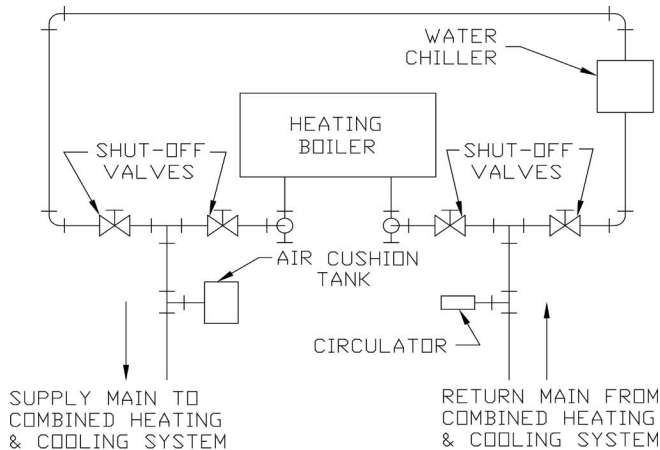

Figure 23: Recommended Piping for Combination Heating and Cooling (Refrigeration) Systems

E. Alliance SL™ Indirect Water Heater (if used). Refer to Alliance SL™ Installation, Operating and Service Instructions for additional information. See Figure 24 for piping recommendations.

1. Supply and Return Piping. Connect supply piping to Tapping "N" (1¼ NPT) and return piping to Tapping "M" (1¼ NPT). Install zone circulator and strainer in supply piping. Install check valve to prevent gravity circulation of boiler water.
2. Limit. See Figure 21. Install temperature limit control (Honeywell L4006A or equal) in Tapping "P" (¾ NPT). See Figure 2. Set at 180°F to prevent steam production during non-space heating periods.

F. If a long term pressure test of the hydronic system is required, the boiler should first be isolated to avoid a pressure loss due to the escape of air trapped in the boiler.

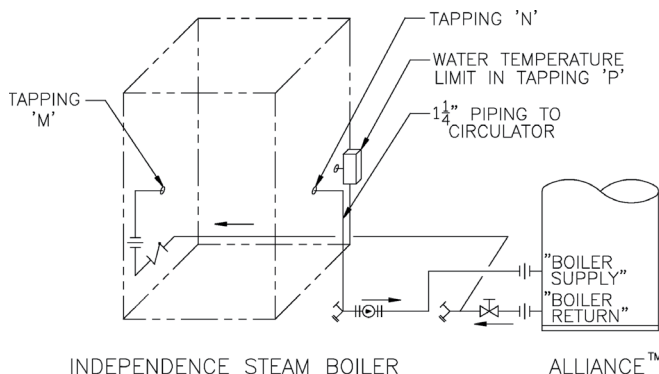

Figure 24: Recommended Piping for Indirect Water Heater

To perform a long term pressure test including the boiler, ALL trapped air must first be removed from the boiler.

A loss of pressure during such a test, with no visible water leakage, is an indication that the boiler contained trapped air.

NOTICE:

Do not use copper for steam piping for the following reasons:

1. High coefficient of thermal expansion can induce mechanical stresses and cause expansion/ contraction noises if not accounted for in piping system design and installation.
2. High heat transfer rate (heat loss) of uninsulated copper piping must be included in normal piping and pickup factors used to size the boiler.
3. Soldering or brazing pastes and fluxes that end up in the system can cause poor heat transfer, surging, an unsteady water line and wet steam if not thoroughly removed during the skimming procedure.
4. Galvanic corrosion of adjoining metal may occur due to dissimilar metals in certain water chemistry if dielectric unions are not used.

6 Gas Piping

WARNING

Indicates a potentially hazardous situation which, if not avoided, could result in death, serious injury or substantial property damage.

A. Size gas Piping. Design system to provide adequate gas supply to boiler. Consider these factors:

1. Allowable pressure drop from point of delivery to boiler. Maximum allowable system pressure is ½ psig. Actual point of delivery pressure may be less; contact gas supplier for additional information. Minimum gas valve inlet pressure shown in Table 3a and boiler rating label.

2. Maximum gas demand. Table 3b lists boiler input rate. Also consider existing and expected future gas utilization equipment (i.e. water heater, cooking equipment).
3. Length of piping and number of fittings. Refer to Table 4 for maximum capacity of Schedule 40 pipe. Table 5 lists equivalent length for standard fittings.
4. Corrections for the specific gravity of natural gas can be found in Table 6.

For materials or conditions other than those listed above, refer to the *National Fuel Gas Code*, ANSI Z223.1/NFPA 54 and/or *Natural Gas and Propane Installation Code*, CAN/CSA B149.1, or size system using standard engineering methods acceptable to authority having jurisdiction.

Table 3a: Minimum Inlet Gas Pressure (inch w.c.)

Boiler Model Number	Natural	LP/Propane
IN3I	4.5	11.0
IN4I	4.5	11.0
IN5I	4.5	11.0
IN6I	4.8	11.0
IN7I	4.5	11.0
IN8I	4.5	11.0
IN9I	4.5	11.0
IN10-I	5.5	---
IN10S	4.5	---
IN11-I	5.5	---
IN11S	4.5	---
IN12-I	5.0	---

Table 3b: Rated Input

Boiler Model Number	Rated Capacity [cubic feet per hour]		Gas Connection Size
	Natural	LP/Propane	
IN3I	62	24 ³ / ₄	½
IN4I	105	42	½
IN5I	140	56	½
IN6I	175	70	½
IN7I	210	84	¾
IN8I	245	98	¾
IN9I	280	112	¾
IN10	315 ⁽¹⁾	---	¾ ⁽²⁾
IN11	349 ⁽¹⁾	---	¾ ⁽²⁾
IN12	385	---	1

⁽¹⁾ Reduce IN10 - IN11 input by 3% in Canada

⁽²⁾ Gas connection size is 1" on IN10 and IN11 Continuous Ignition (Standing Pilot)

WARNING

- Failure to use proper thread compounds on all gas connectors may result in leaks of flammable gas. .
- Gas supply to boiler and system must be absolutely shut off prior to installing or servicing boiler gas piping.

B. Connect boiler gas valve to gas supply system.

1. Use methods and materials in accordance with local plumbing codes and requirements of gas supplier. In absence of such requirements, follow the *National Fuel Gas Code*, ANSI Z223.1/NFPA 54 and/or *Natural Gas and Propane Installation Code*, CAN/CSA B149.1.
2. Use thread (joint) compounds (pipe dope) resistant to action of liquefied petroleum gas.
3. Install sediment trap, ground-joint union and manual shut-off valve upstream of boiler gas valve and outside jacket. See Figure 25.
4. All above ground gas piping upstream from manual gas valve must be electrically continuous and bonded to a grounding electrode. Do not use gas piping as a grounding electrode. Refer to the *National Electrical Code*, ANSI/NFPA 70 and/or CSA C22.1 Electrical Code.

C. Pressure Test. The boiler and its gas connection must be leak tested before placing boiler in operation.

1. Protect boiler gas valve. For all testing over ½ psig (3.5 kPa), boiler an its individual shut-off valve must be disconnected from gas supply piping. For testing at pressure equal to or less than ½ psig (3.5 kPa), isolate boiler from gas supply piping by closing boiler's individual manual shut-off valve.

6 Gas Piping (continued)

Table 4: Maximum Capacity of Schedule 40 Pipe in CFH for Natural Gas Pressures of 0.5 psig or Less

Length\ [Feet]	0.3 inch w.c. Pressure Drop				0.5 inch w.c. Pressure Drop			
	1/2	3/4	1	1 1/4	1/2	3/4	1	1 1/4
10	132	278	520	1,050	175	360	680	1,400
20	92	190	350	730	120	250	465	950
30	73	152	285	590	97	200	375	770
40	63	130	245	500	82	170	320	660
50	56	115	215	440	73	151	285	580
60	50	105	195	400	66	138	260	530
70	46	96	180	370	61	125	240	490
80	43	90	170	350	57	118	220	460
90	40	84	160	320	53	110	205	430
100	38	79	150	305	50	103	195	400

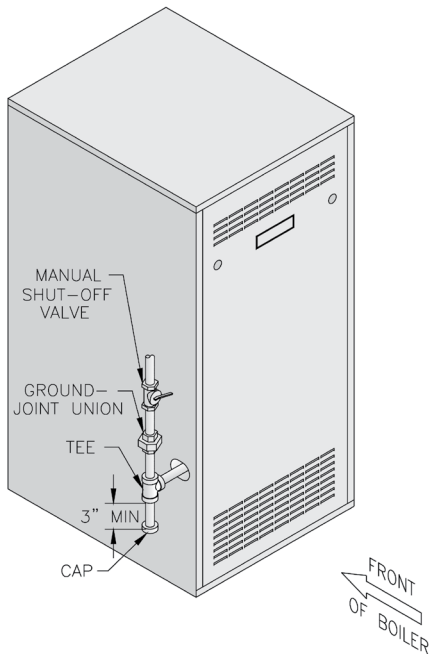

Figure 25: Recommended Gas Piping

- Using soap solution, or similar non-combustible solution, electronic leak detector or other approved method. Check that boiler gas piping valves, and all other components are leak free. Eliminate any leaks.

⚠ DANGER

Do not use matches, candles, open flames or other ignition source to check for leaks.

Table 5: Fitting Equivalent Lengths

Fitting	Nominal Pipe Size			
	1/2	3/4	1	1 1/4
45° Ell	0.7	1.0	1.2	1.6
90° Ell	1.6	2.1	2.6	3.5
Tee (As Elbow)	3.1	4.1	5.2	6.9

Table 6: Specific Gravity Correction Factors for Natural Gas

Specific Gravity	Correction Factor	Specific Gravity	Correction Factor
0.50	1.10	1.30	1.07
0.55	1.04	1.40	1.04
0.60	1.00	1.50	1.00
0.65	0.96	1.60	0.97
0.70	0.93	1.70	0.94
0.75	0.90		
0.80	0.87		

NOTICE USA boilers built for installation at altitudes greater than 2,000 feet above sea level have been specially orificed to reduce gas input rate 4 percent per 1,000 feet above sea level per the National Fuel Gas Code, NFPA 54/ANSI Z223.1. Canadian boilers' orifice sizing is indicated on the rating label. High altitude boiler models are identifiable by the third digit in the model number suffix on the rating label:

- IN - 2 less than 2000 ft. elevation
- IN - 4 2000 to 4500 ft. elevation (Canada)
- IN - 5 2000 to 5000 ft. elevation (USA)

7 Venting

WARNING

- This boiler needs fresh air for safe operation and must be installed so there are provisions for adequate combustion and ventilation air.
- Read, understand and follow combustion air instruction restrictions contained in the Pre-Installation instructions of this manual.
- Do not operate boiler where gasoline or other flammable vapors or liquids, or sources of hydrocarbons (i.e. bleaches, cleaners, chemicals, sprays, paint removers, fabric softeners, etc.) are used, stored and/or present in the air.

A. Install vent system in accordance with local building codes; or local authority having jurisdiction; or "Venting of Equipment", of the *National Fuel Gas Code*, ANSI Z223.1/NFPA 54, or "Venting Systems and Air Supply for Appliances", of the *National Gas and Propane Installation Code*, CAN/CSA B149.1.

Install any of the following for this Independence Series Category I, draft hood equipped appliance:

1. Type B or Type L gas vent. Install in accordance with listing and manufacturer's instructions.
2. Masonry or metal chimney. Build and install in accordance with local building codes; or local authority having jurisdiction; or *Standard for Chimneys, Fireplaces, Vents, and Solid Fuel Burning Appliances*, ANSI/NFPA 211 and/or *National Building Code of Canada*.
Masonry chimney must be lined with approved clay flue lining or listed chimney lining system.
3. Single wall metal vent. Allowed by ANSI Z223.1/NFPA 54 under very restrictive conditions.
4. Do not use cellular core PVC (ASTM F891), cellular core CPVC, or Radel® (polyphenolsulfone).
5. Do not cover non-metallic vent pipe and fittings with thermal insulation. Note: Non-metallic vent cannot be used with this boiler.

B. Inspect chimney and remove any obstructions or restrictions. Clean chimney if previously used for solid or liquid fuel-burning appliances or fireplaces.

DANGER

Inspect existing chimney before installing boiler. Failure to clean or replace perforated pipe or tile lining will cause severe injury or death.

C. Boiler Equipped With Vent Damper

1. Open Vent Damper Carton and remove Installation Instructions. Read Installation Instructions thoroughly before proceeding.

CAUTION

Do not use one vent damper to control two heating appliances.

Provide adequate clearance for servicing - 6" (152 mm) minimum clearance between damper and combustible construction.

NOTICE DO NOT force the vent damper over the rolled bead on the draft hood collar. The vent damper should rest on the rolled bead.

Please refer to the specifications, installation instructions and trouble shooting guide packed in the vent damper carton for complete detailed installation instructions.

2. Vent damper should be same size as draft hood outlet. See Figure 1. Unpack vent damper carefully - **DO NOT FORCE CLOSED!** Forcing vent damper may damage gear train and void warranty. Vent damper assembly includes pre-wired connection harness with polarized plug for use on all 24V standing pilot or intermittent ignition (EI) control systems.
3. Mount vent damper assembly on draft hood without modification to either (Refer to instructions packed with vent damper for specific instructions). Vent damper position indicator to be visible to users following installation.
4. USA - Do not install Non-listed vent damper or other obstruction in vent pipe.
Canada - Do not install Non-listed vent damper or other obstruction in vent pipe.
5. Arrange venting system so only the boiler is served by vent damper supplied with boiler.

D. Install Vent Connector from draft hood or vent damper to chimney. See Figure 26.

1. Do not connect into same leg of chimney serving an open fireplace.
2. Vent pipe to chimney must not be smaller than outlet on draft hood or vent damper. Type B is recommended, but single-wall vent pipe may be used. Arrange venting system so boiler is served by vent damper device.

7 Venting *(continued)*

Exception: *National Fuel Gas Code, ANSI Z223.1/ NFPA 54, and Natural Gas and Propane Installation Code, CAN/CSA B149.1*, allow vent downsizing when vent size determined by their Vent Sizing Tables is smaller than draft hood outlet/vent damper. These codes require all of the following:

- (a) Total vent height (H) is at least 10 ft (3 m);
 - (b) Vent not reduced more than one table size; and
 - (c) Draft hood outlet/vent damper is greater than 4 in. (102 mm) in diameter (IN3I cannot use smaller vent size).
3. Where two or more appliances vent into a common vent, the area of the common vent should be at least equal to the area of the largest vent plus 50% of the area in the additional vent(s).
 4. Vent connectors serving appliances vented by natural draft shall not be connected into any portion of mechanical draft systems operating under positive pressure.
 5. Horizontal run should be as short as possible. The maximum length of an uninsulated horizontal run must not exceed 75% of the height of the chimney.
 6. Vent pipe should have the greatest possible initial rise above draft hood consistent with headroom available and required clearance from adjacent combustible building structure. Vent pipe should be installed above bottom of chimney to prevent blockage.
 7. Slope horizontal portions of vent pipe upwards not less than 1/4 in/ft (21 mm/m) from boiler to vent terminal.

les chaudières de catégories I doivent présenter des tronçons horizontaux dont la pente montante est d'au moins 1/4 po par pied (21 mm/m) entre la chaudière et l'évent.

8. Support horizontal portions of venting system to prevent sagging. Use pipe straps, brackets or hangers spaced 4 ft (1.2 m) or less.
Soutenez parties horizontales de ventilation pour éviter l'affaissement. Utilisez des colliers de serrage, des crochets ou cintres espacées de 4 pieds (1,2 m) ou moins.
9. Vent pipe must be inserted into but not beyond inside wall of chimney liner. Seal tight between vent pipe and chimney.

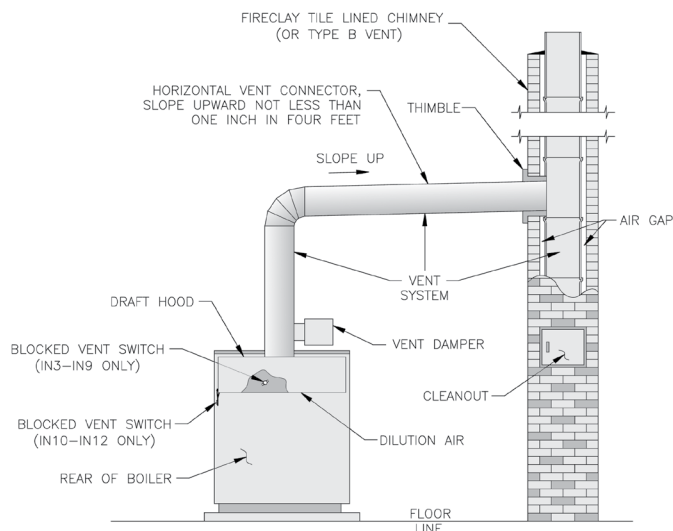

Figure 26: Typical Vent Installation

E. If an Existing Boiler is Removed:

When an existing boiler is removed from a common venting system, the common venting system is likely to be too large for proper venting of the appliances remaining connected to it.

At the time of removal of an existing boiler, the following steps shall be followed with each appliance remaining connected to the common venting system placed in operation, while the other appliances remaining connected to the common venting system are not in operation:

1. Seal any unused openings in the common venting system.
2. Visually inspect the venting system for proper size and horizontal pitch and determine there is no blockage or restriction, leakage, corrosion, and other deficiencies which could cause an unsafe condition.
3. Insofar as is practical, close all building doors and windows and all doors between the space in which the appliances remaining connected to the common venting system are located and other spaces of the building. Turn on clothes dryers and any appliance not connected to the common venting system. Turn on any exhaust fans, such as range-hoods and bathroom exhausts, so they will operate at maximum speed. Do not operate a summer exhaust fan. Close fireplace dampers.
4. Place in operation the appliance being inspected. Follow the Lighting (or Operating) Instructions. Adjust thermostat so appliance will operate continuously.

7 Venting *(continued)*

5. Test for spillage at the draft hood relief opening after 5 minutes of main burner operation. Use the flame of a match or candle, or smoke from a cigarette, cigar or pipe.
6. After it has been determined that each appliance remaining connected to the common venting system properly vents when tested as outlined above, return doors, windows, exhaust fans, fireplace dampers and any other gas-burning appliance to their previous condition of use.
7. Any improper operation of the common venting system should be corrected so the installation conforms with the *National Fuel Gas Code*, ANSI Z223.1/NFPA 54, and/or the *Natural Gas and Propane Installation Code*, CAN/CSA B149.1. When resizing any portion of the common venting system, the common venting system should be resized to approach the minimum size as determined using the appropriate tables in Appendix F in the *National Fuel Gas Code*, ANSI Z223.1/NFPA 54, and/or the *Natural Gas and Propane Installation Code*, CAN/CSA B149.1.

Au moment du retrait d'une chaudière existante, les mesures suivantes doivent être prises pour chaque appareil toujours raccordé au système d'évacuation commun et qui fonctionne alors que d'autres appareils toujours raccordés au système d'évacuation ne fonctionnent pas:

1. Sceller toutes les ouvertures non utilisées du système d'évacuation.
2. Inspecter de façon visuelle le système d'évacuation pour déterminer la grosseur et l'inclinaison horizontale qui conviennent et s'assurer que le système est exempt d'obstruction, d'étranglement, de fuite, de corrosion et autres défaillances qui pourraient présenter des risques.

3. Dans la mesure du possible, fermer toutes les portes et les fenêtres du bâtiment et toutes les portes entre l'espace où les appareils toujours raccordés au système d'évacuation sont installés et les autres espaces du bâtiment. Mettre en marche les sècheuses, tous les appareils non raccordés au système d'évacuation commun et tous les ventilateurs d'extraction comme les hottes de cuisinière et les ventilateurs des salles de bain. S'assurer que ces ventilateurs fonctionnent à la vitesse maximale. Ne pas faire fonctionner les ventilateurs d'été. Fermer les registres des cheminées.
4. Mettre l'appareil inspecté en marche. Suivre les instructions d'allumage. Régler le thermostat de façon que l'appareil fonctionne de façon continue.
5. Faire fonctionner le brûleur principal pendant 5 min ensuite, déterminer si le coupe-tirage déborde à l'ouverture de décharge. Utiliser la flamme d'une allumette ou d'une chandelle ou la fumée d'une cigarette, d'un cigare ou d'une pipe.
6. Une fois qu'il a été déterminé, selon la méthode indiquée ci-dessus, que chaque appareil raccordé au système d'évacuation est mis à l'air libre de façon adéquate. Remettre les portes et les fenêtres, les ventilateurs, les registres de cheminées et les appareils au gaz à leur position originale.
7. Tout mauvais fonctionnement du système d'évacuation commun devrait être corrigé de façon que l'installation soit conforme au *National Fuel Gas Code*, ANSI Z223.1/NFPA 54 et (ou) aux codes d'installation CAN/CSA-B149.1. Si la grosseur d'une section du système d'évacuation doit être modifiée, le système devrait être modifié pour respecter les valeurs minimales des tableaux pertinents de l'appendice F du *National Fuel Gas Code*, ANSI Z223.1/NFPA 54 et (ou) des codes d'installation CAN/CSA-B149.1.

8 Electrical

⚠ DANGER

Positively assure all electrical connections are unpowered before attempting installation or service of electrical components or connections of the boiler or building. Lock out all electrical boxes with padlock once power is turned off.

⚠ WARNING

- Failure to properly wire electrical connections to the boiler may result in serious physical harm.
- Electrical power may be from more than one source. Make sure all power is off before attempting any electrical work.
- Each boiler must be protected with a properly fused disconnect.
- Never jump out or make inoperative any safety or operating controls.

A. General. Install wiring and ground boiler in accordance with requirements of authority having jurisdiction, or in absence of such requirements the *National Electrical Code*, ANSI/NFPA 70 and/or the *Canadian Electrical Code Part 1*, CSA 22.1, *Electrical Code*.

B. Wire Vent Damper (if used).

1. Steam or tankless heater.
 - a. Remove one (1) 7/8" knockout from junction box. Carefully remove transformer - avoid undue strain on wires.
 - b. Install Vent Damper Harness into top of junction box.
 - c. Remove factory installed jumper plug (if so equipped) from Vent Damper Receptacle. Plug Vent Damper Harness into Vent Damper Receptacle. See Figure 28.
 - d. Install cable clamp around flexible Vent Damper Harness. Attach to jacket top panel. See Figure 29.
2. Note: After vent damper is installed and operated through one (1) cycle, the control circuit will operate only when vent damper is in control circuit.

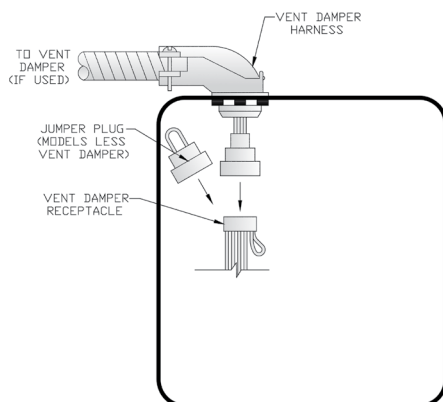

Figure 28: Vent Damper Connection Detail

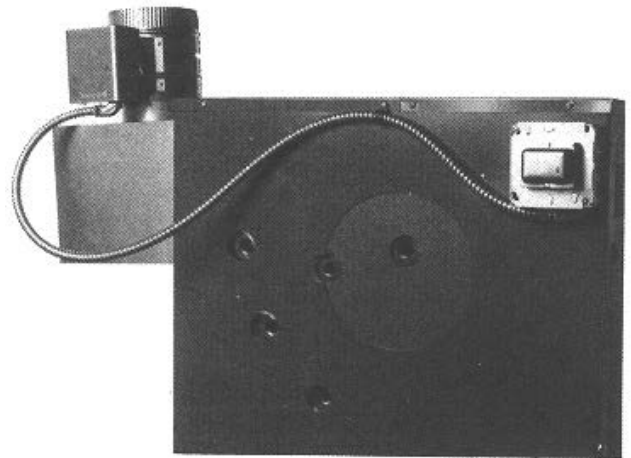

Figure 29: Vent Damper Harness to Junction Box

C. Install thermostat. Locate on inside wall approximately 4 feet above floor. Do not install on outside wall, near fireplace, or where influenced by drafts or restricted air flow, hot or cold pipes, lighting fixtures, television, or sunlight. Allow free air movement by avoiding placement of furniture near thermostat.

Set heat anticipator to match system requirements. See Table 7. In general, setting heat anticipator too low will cause boiler to short cycle without bringing heated space up to temperature. Setting heat anticipator too high will allow boiler to operate longer than necessary and overheat space.

D. Wire thermostat. Provide Class II circuit between thermostat and boiler.

1. Steam or tankless heater. Remove transformer from junction box. Connect one wire from thermostat to blue wire(s). Connect additional wire from thermostat to brown wire or red wire for water with tankless heater.

8 Electrical *(continued)*

E. Alliance SL™ Indirect Water Heater (if used).

1. For wiring refer to wiring diagrams located in this section and Alliance SL™ Installation Operating and Service Instructions.
2. Attach junction box extension (4 - 11/16 square) to junction box on boiler.
3. Steam Boilers only. Verify temperature limit (Honeywell L4006 or equal, which is installer supplied) is installed in Tapping "P", refer to Section V: Piping and Trim.

F. Wire control circuit as shown in the appropriate wiring diagram. See Table 7.

1. A separate electrical circuit must be run from the main electrical service with an over-current device/disconnect in the circuit. A service switch is recommended and may be required by some local jurisdictions. Boiler is rated for 120 VAC, 60 hertz, less than 12 amperes.
2. For zone valve wiring, provide separate 24V transformer rather than attempting to use boiler mounted control. Consult zone valve manufacturer for assistance.

G. Wiring diagram and sequence of operation.

Locate the system type you are interested in from Table 7, then refer to the page indicated.

1. Vent Damper Sequence of Operation. See Figure 30.
 - a. Vent Damper is continuously powered at Terminal 1.
 - b. When there is a call for heat, the damper relay coil is energized through Terminal 5 if all limits ahead of the damper are satisfied.
 - c. Relay coil closes contacts, energizing damper motor, causing damper to open.
 - d. When the damper blade reaches the fully open position, power is sent back to the boiler limit/ignition circuit through Terminal 2 and the damper motor is de-energized.
 - e. When the call for heat is satisfied, the damper relay coil is de-energized—closing contacts which energize the damper motor. This causes the damper to close. When the damper blade reaches the fully closed position, the damper motor is de-energized.

Table 7: Thermostat Heat Anticipator Settings

System Type	Ignition System	Heat Anticipator Setting ⁽¹⁾
	Intermittent (EI) All Sizes	
Probe (McDonnell & Miller PS-802 or Hydrolevel CGB-400) Low Water Cutoff	Figure 32, Page 29	0.8
Float (McDonnell & Miller 67) Low Water Cutoff	Figure 34, Page 33	0.8

⁽¹⁾ If system tends to overheat above thermostat's temperature setting, reduce heat anticipator setting by 0.1 or 0.2 amps. If system tends to shortcycle without reaching desired room temperature, increase heat anticipator setting by 0.1 or 0.2 amps.

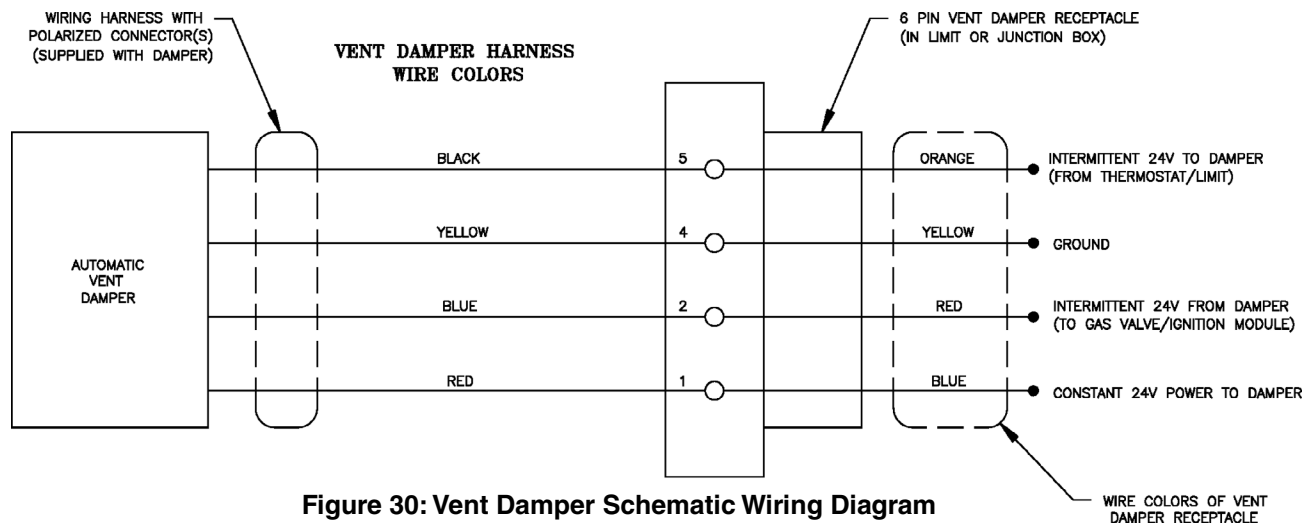

Figure 30: Vent Damper Schematic Wiring Diagram

8 Electrical *(continued)*

H. Safety Shutdown

- a. Limit: Automatically interrupts main burner operation when steam pressure exceeds set point. Maximum allowable pressure is 15 psi. Normal operation resumes when system pressure falls below set point.
- b. Low Water Cutoff (LWCO): Automatically interrupts main burner operation when surface of boiler water falls to lowest permissible operating level. Normal operation resumes when water returns to normal level.
- c. Blocked Vent Switch. Automatically interrupts main burner operation when excessive vent system blockage occurs. Control is a multiple use device. If blocked vent switch is activated do not attempt to place boiler in operation. Correct source of blockage and reset blocked vent switch.
- d. Flame Roll-out Switch. Automatically interrupts boiler operation when flames or excessive heat are present in vestibule. Control is single use device. If flame roll-out switch is activated do not attempt to place boiler in operation. Correct source of blockage and replace flame roll-out switch.
- e. Thermocouple: senses pilot flame and causes gas valve to turn off main burner and pilot burner gas flow should pilot burner flame extinguish.

8 Electrical *(continued)*

- I. Steam Boiler with Intermittent Ignition (EI) and Probe Low Water Cutoff. See Figure 31.
1. Normal Operation
 - a. Thermostat calls for heat. Thermostat Isolation Relay is energized, closing contacts.
 - b. Vent Damper (if used) opens as stated in Vent Damper Sequence of Operation.
 - c. Ignition Module is energized. Pilot Valve opens and Igniter is energized to ignite Pilot Burner.
 - d. Sensor proves presence of pilot flame. Main Valve(s) opens and ignites Main Burners. Vent damper, if used, must be in open position when appliance main burners are operating.

Le registre doit être ouvert lorsque le brûleur principal de l'appareil fonctionne.
 - e. After Thermostat is satisfied Ignition Module is de-energized, extinguishing pilot and main flame. Vent Damper (if used) closes.
 2. Safety Shutdown
 - a. Limit: Automatically interrupts main burner operation when steam pressure exceeds set point. Maximum allowable pressure is 15 psi. Normal operation resumes when system pressure falls below set point.
 - b. Low Water Cutoff (LWCO): Automatically interrupts main burner operation when surface of boiler water falls to lowest permissible operating level. Normal operation resumes when water returns to normal level.
 - c. Blocked Vent Switch. Automatically interrupts main burner operation when excessive vent system blockage occurs. Control is a multiple use device. If blocked vent switch is activated do not attempt to place boiler in operation. Correct source of blockage and reset blocked vent switch.
 - d. Flame Roll-out Switch. Automatically interrupts boiler operation when flames or excessive heat are present in vestibule. Control is single use device. If flame roll-out switch is activated do not attempt to place boiler in operation. Correct source of blockage and replace flame roll-out switch.
 - e. Igniter/Sensor: senses pilot flame and causes ignition module to turn off main burner and pilot burner gas flow should pilot burner flame extinguish. Five to six minutes after shutdown, Ignition Module restarts ignition sequence.

For Electronic Ignition Trouble Shooting Guide, see Page 50. For LED Status Codes, see Table 9 on Page 39.

8 Electrical *(continued)*

J. Safety Shutdown

- a. Limit: Automatically interrupts main burner operation when steam pressure exceeds set point. Maximum allowable pressure is 15 psi. Normal operation resumes when system pressure falls below set point.
- b. Low Water Cutoff (LWCO): Automatically interrupts main burner operation when surface of boiler water falls to lowest permissible operating level. Normal operation resumes when water returns to normal level.
- c. Blocked Vent Switch. Automatically interrupts main burner operation when excessive vent system blockage occurs. Control is a multiple use device. If blocked vent switch is activated do not attempt to place boiler in operation. Correct source of blockage and reset blocked vent switch.
- d. Flame Roll-out Switch. Automatically interrupts boiler operation when flames or excessive heat are present in vestibule. Control is single use device. If flame roll-out switch is activated do not attempt to place boiler in operation. Correct source of blockage and replace flame roll-out switch.
- e. Thermocouple: senses pilot flame and causes gas valve to turn off main burner and pilot burner gas flow should pilot burner flame extinguish.

8 Electrical (continued)

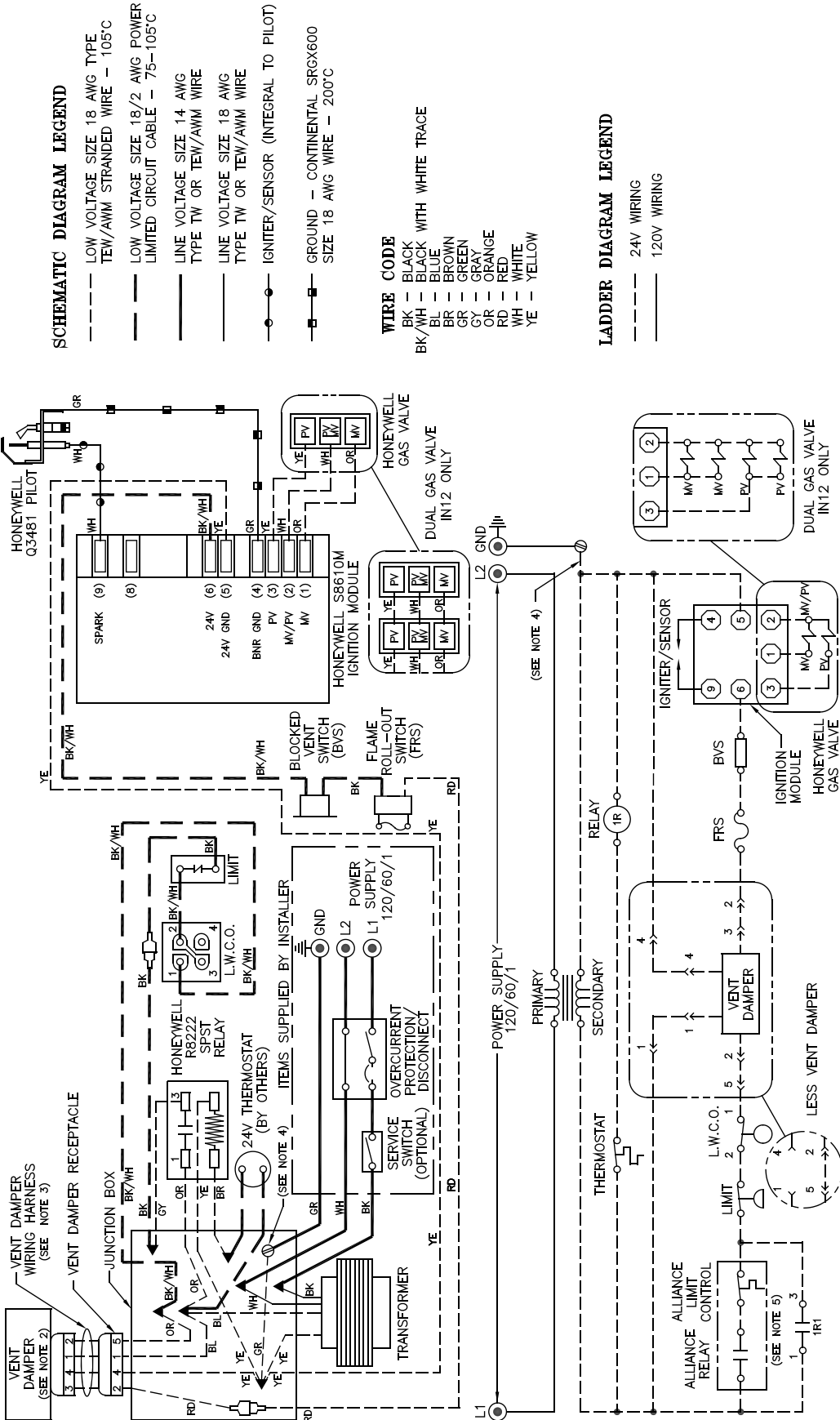

SCHEMATIC DIAGRAM LEGEND

- LOW VOLTAGE SIZE 18 AWG TYPE TEW/AWM STRANDED WIRE - 105°C
- LOW VOLTAGE SIZE 18/2 AWG POWER LIMITED CIRCUIT CABLE - 75-105°C
- LINE VOLTAGE SIZE 14 AWG TYPE TW OR TEW/AWM WIRE
- LINE VOLTAGE SIZE 18 AWG TYPE TW OR TEW/AWM WIRE
- IGNITER/SENSOR (INTEGRAL TO PILOT)
- GROUND - CONTINENTAL SRGX600 SIZE 18 AWG WIRE - 200°C

WIRE CODE

- BK - BLACK
- BK/WH - BLACK WITH WHITE TRACE
- BL - BLUE
- BR - BROWN
- GR - GREEN
- GY - GRAY
- OR - ORANGE
- RD - RED
- WH - WHITE
- YE - YELLOW

LADDER DIAGRAM LEGEND

- 24V WIRING
- 120V WIRING

NOTES:

1. IF ANY OF THE ORIGINAL WIRE AS SUPPLIED WITH THE APPLIANCE MUST BE REPLACED, IT MUST BE REPLACED WITH WIRE AS SHOWN OR ITS EQUIVALENT. SI UN DES CONDUCTEURS FOURNI AVEC L'APPAREIL DOIT ÊTRE REMPLACÉ, UTILISER UN CONDUCTEUR COMME LE MONTRÉ OU L'ÉQUIVALENT.
2. VENT DAMPER REQUIRED FOR MODELS IN31 THRU IN91. VENT DAMPER OPTIONAL FOR IN10 THRU IN12.
3. FOR BOILER LESS VENT DAMPER ONLY. VENT DAMPER WIRING HARNESS REPLACED WITH JUMPER PLUG.
4. CANADA ONLY - ATTACH GREEN GROUND WIRE FROM TRANSFORMER SECONDARY TO GREEN GROUND SCREW.
5. WATER HEATER CONTROLS SUPPLIED BY INSTALLER.

Figure 32: Wiring Diagrams, Steam, Intermittent Ignition (EI), Float Low Water Cutoff

8 Electrical *(continued)*

K. Steam Boiler with Intermittent Ignition (EI) and Float Low Water Cutoff. See Figure 32.

1. Normal Operation

- a. Thermostat calls for heat. Thermostat Isolation Relay is energized, closing contacts.
- b. Vent Damper (if used) opens as stated in Vent Damper Sequence of Operation.
- c. Ignition Module is energized. Pilot Valve opens and Igniter is energized to ignite Pilot Burner.
- d. Sensor proves presence of pilot flame. Main Valve(s) opens and ignites Main Burners. Vent damper, if used, must be in open position when appliance main burners are operating.

Le registre doit être ouvert lorsque le brûleur principal de l'appareil fonctionne.

- e. After Thermostat is satisfied Ignition Module is de-energized, extinguishing pilot and main flame. Vent Damper (if used) closes.

2. Safety Shutdown

- a. Limit: Automatically interrupts main burner operation when steam pressure exceeds set point. Maximum allowable pressure is 15 psi. Normal operation resumes when system pressure falls below set point.

- b. Low Water Cutoff (LWCO): Automatically interrupts main burner operation when surface of boiler water falls to lowest permissible operating level. Normal operation resumes when water returns to normal level.
- c. Blocked Vent Switch. Automatically interrupts main burner operation when excessive vent system blockage occurs. Control is a multiple use device. If blocked vent switch is activated do not attempt to place boiler in operation. Correct source of blockage and reset blocked vent switch.
- d. Flame Roll-out Switch. Automatically interrupts boiler operation when flames or excessive heat are present in vestibule. Control is single use device. If flame roll-out switch is activated do not attempt to place boiler in operation. Correct source of blockage and replace flame roll-out switch.
- e. Igniter/Sensor: senses pilot flame and causes ignition module to turn off main burner and pilot burner gas flow should pilot burner flame extinguish. Five to six minutes after shutdown, Ignition Module restarts ignition sequence.

For Electronic Ignition Trouble Shooting Guide, see Page 50. For LED Status Codes, see Table 9 on Page 39.

9 System Start-Up

⚠ WARNING

Indicates a potentially hazardous situation which, if not avoided, could result in death, serious injury or substantial property damage.

- A. Safe lighting** and other performance criteria were met with the gas manifold and control assembly provided on boiler when boiler underwent tests specified in *American National Standard for Gas-Fired Low-Pressure Steam and Hot Water Boilers*, ANSI Z21.13.
- B. Check Main Burners.** Main burners must be in slots in rear of burner tray and seated on main burner orifices.
- C. Fill boiler with water:**
 1. Steam: fill to normal water line. See Figure 1.
- D. Prepare to check operation.**
 1. Obtain gas heating value (in Btu per cubic foot) from gas supplier.
 2. Adjust limit:
 - a. Steam: With an L404A1354 - set cut-out pressure (MAIN scale) on the pressure limit for (2) PSI and differential pressure (DIFF. scale) below (2) PSI. With an L404A1651 or an L404F1367 - set cut-out pressure (MAIN scale) on the pressure limit for (1) PSI and differential pressure (DIFF.) for .5 PSI. These pressures may be varied to suit individual requirements of the system. See Figure 16.
 3. Remove front removable panel. See Figure 35.
 4. Connect manometer to gas valve pressure tapping (for IN12 connect to gas valve with pilot control). See Figure 36 or 37.
 5. For natural gas fired boiler, temporarily turn off all other gas-fired appliances.

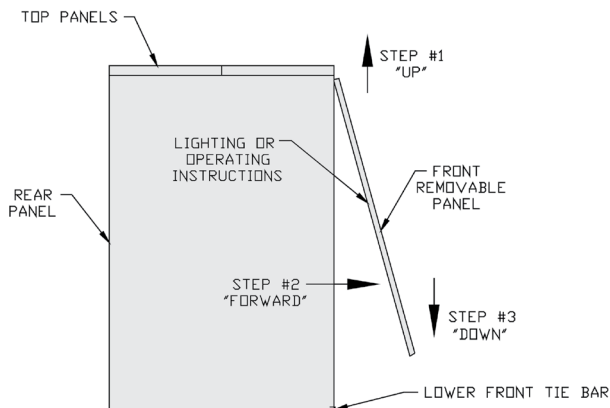

SIDE VIEW
Figure 35: Front Door Removal

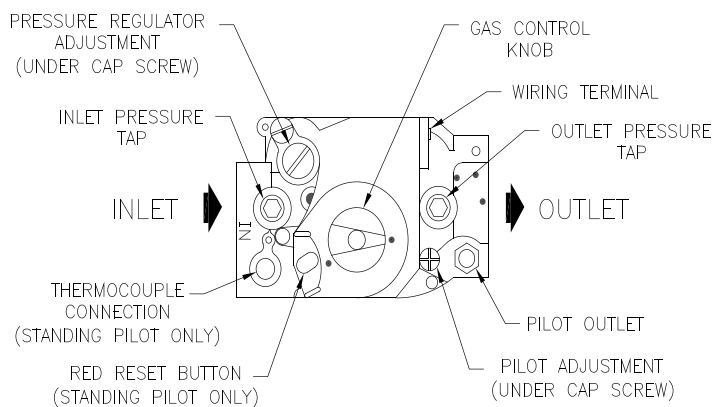
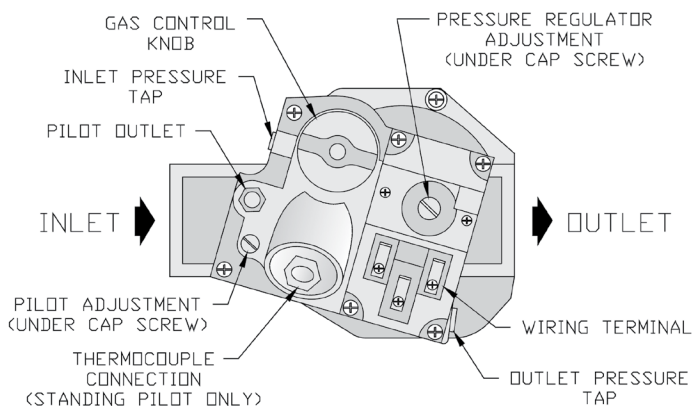

Figure 36: Gas Valve Pressure Tap, Honeywell Gas Valves



TOP VIEW OF ROBERTSHAW GAS VALVE

Figure 37: Gas Valve Pressure Tap, Robertshaw Gas Valve

E. Follow Lighting or Operating Instructions.

1. To place boiler in operation. See Figure 38, 39 or 40. Sequence of Operation is outlined with wiring diagrams in Section VIII: Electrical.

2. Enhanced Electronic Ignition Module with single Status LED indicator. See Figure 41A "Location of LED".

Table 8 "Ignition Module Terminal Cross-reference" cross-references the ignition module terminal designations to the ignition terminal numbers in the wiring ladder diagrams.

Table 9 "Green LED Status Codes" provides green LED status codes and recommended service action where applicable.

See Page 50 for Troubleshooting Guide.

3. Flame Current Measurement Procedure See Figure 41B "Measuring Pilot Flame Current with Micro-ammeter".
 - a. Pilot flame current in micro amps can be measured using any standard micro-ammeter by inserting the meter probes into the module holes labeled FLAME CURRENT as shown in Figure 41B.

9 System Start-Up *(continued)*

FOR YOUR SAFETY READ BEFORE OPERATING/POUR VOTRE SECURITE LISEZ AVANT DE METTRE EN MARCHE

WARNING: If you do not follow these instructions exactly, a fire or explosion may result causing property damage, personal injury or loss of life.

AVERTISSEMENT: Quiconque ne respecte pas à la lettre les instructions dans la présente notice risque de déclencher un incendie ou une explosion entraînant des dommages, des blessures ou la mort.

- A. This appliance is equipped with an ignition device which automatically lights the burner. Do not try to light the burner by hand.
- B. BEFORE OPERATING smell all around the appliance area for gas. Be sure to smell next to the floor because some gas is heavier than air and will settle on the floor.

WHAT TO DO IF YOU SMELL GAS:

- Do not try to light any appliance.
- Do not touch any electric switch; do not use any phone in your building.
- Immediately call your gas supplier from a neighbor's phone. Follow the gas supplier's instructions.
- If you cannot reach your gas supplier, call the fire department.

- C. Use only your hand to push in or turn the gas control knob. Never use tools. If the knob will not turn by hand, don't try to repair it, call a qualified service technician. Force or attempted repair may result in a fire or explosion.
- D. Do not use this appliance if any part has been under water. Immediately call a qualified service technician to inspect the appliance and to replace any part of the control system and any gas control which has been under water.

- A. Cet appareil est muni d'un dispositif d'allumage qui allume automatiquement la veilleuse. Ne tentez pas d'allumer la veilleuse manuellement.
- B. AVANT DE FAIRE FONCTIONNER, reniflez tout autour de l'appareil pour détecter une odeur de gaz. Reniflez près du plancher, car certains gaz sont plus lourds que l'air et peuvent s'accumuler au niveau du sol.

QUE FAIRE SI VOUS SENTEZ UNE ODEUR DE GAZ:

- Ne pas tenter d'allumer d'appareil.
- Ne touchez à aucun interrupteur ; ne pas vous servir des téléphones se trouvant dans le bâtiment.
- Appelez immédiatement votre fournisseur de gaz depuis voisin. Suivez les instructions du fournisseur.
- Si vous ne pouvez rejoindre le fournisseur, appelez le service des incendies.

- C. Ne poussez ou tournez la manette d'admission du gaz qu'à la main; ne jamais utiliser d'outil. Si la manette reste coincée, ne pas tenter de la réparer; appelez un technicien qualifié. Le fait de forcer la manette ou de la réparer peut déclencher une explosion ou un incendie.
- D. N'utilisez pas cet appareil s'il a été plongé dans l'eau, même partiellement. Faites inspecter l'appareil par un technicien qualifié et remplacez toute partie du système de contrôle et toute commande qui ont été plongés dans l'eau.

OPERATING INSTRUCTIONS/INSTRUCTIONS DE FONCTIONNEMENT

1. STOP! Read safety information above (to the left) on this label.
2. Set the thermostat to lowest setting.
3. Turn off all electric power to the appliance.
4. This appliance is equipped with an ignition device which automatically lights the burner. Do not try to light the burner by hand.
5. Remove front door.
6. Locate the gas control valve at the end of the gas supply pipe going into the boiler. The gas control is the brown or blue plastic knob located on top of the gas control valve.
7. Rotate gas control knob clockwise ↻ from "ON" position to "OFF". Make sure knob rests against stop.
8. Wait five (5) minutes to clear out any gas. Then smell for gas, including near the floor. If you smell gas, STOP! Follow "B" in the safety information above (to the left) on this label. If you don't smell gas, go to the next step.
9. Rotate gas control knob counterclockwise ↺ from "OFF" to "ON". Make sure knob rest against stop. Do not force.
10. Replace front door.
11. Turn on all electric power to the appliance.
12. Set the thermostat to the desired setting.
13. If the appliance will not operate, follow the instructions "To Turn Off Gas To Appliance" and call your service technician or gas supplier.

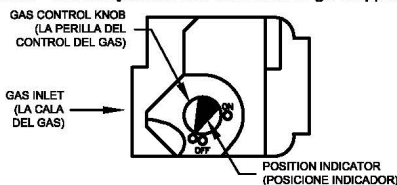

1. ARRÊTEZ ! Lisez les instructions de sécurité sur la portion supérieure (a gauche) cette étiquette.
2. Réglez le thermostat à la température la plus basse.
3. Coupez l'alimentation électrique de l'appareil.
4. Cet appareil est équipé de l' dispositif d'allumage qui automobile allume maticallyle brûleur. Ne pas essayer d'allumer le brûleur près main.
5. Enlevez la porte de devant.
6. Localisez la valve du controle du Gaz a la fin du depart de la pipe de la provision du gaz dans l'appareil. Le bouton plastique brun ou bleu localise sur la valve du controle du gaz. Voyez le diagramme.
7. Faites pivoter le bouton de contrôle du gaz dans le sens inverse ↺ des aiguilles d'une montre de "OFF" pour "ON".
8. Attendez cinq (5) minutes pour laisser échapper tout le gaz. Reniflez tout autour de l'appareil, y compris près du plancher, pour détecter une odeur de gaz, ARRÊTEZ ! Passez à l'étape B des instructions de sécurité sur la portion supérieure (a gauche) cette étiquette. S'il n'y a pas d'odeur de gaz, passez à l'étape suivante.
9. Faites pivoter gas contrôle bouton clockwise from ↻ la position "ON" à "OFF". Assurez-vous que pommeau repose contre stop. Ne forcez pas.
10. Remplacer la porte de devant.
11. Allumer toute l'énergie électrique au appareil.
12. Réglez le thermostat à la température désirée.
13. Si l'appareil ne se met pas en marche, suivez les instructions intitulées "Comment couper l'admission de gaz de l'appareil" et appelez un technicien qualifié ou le fournisseur de gaz.

TO TURN OFF GAS TO APPLIANCE/COMMENT COUPER L'ADMISSION DE GAZ DE L'APPAREIL

1. Set the thermostat to lowest setting.
2. Turn off all electric power to the appliance if service is to be performed.
3. Remove front door.
4. Rotate gas control knob clockwise ↻ from "ON" position to "OFF". Make sure knob rests against stop.
5. Replace front door.

1. Regler le thermostat au plus bas regle.
2. Coupez l'alimentation électrique de l'appareil si le service devrait être exécuté.
3. Enlever la porte de devant.
4. Tourner le gaz regle le bouton dans le sens des aiguilles d'une montre a partir ↻ de position a de. Assurer que le se repose contre arete.
5. Remplacer le porte de devant

103028-02

Figure 38: Operating Instructions, Intermittent Ignition System, VR8204 and VR8304 (except IN12) Gas Valves

9 System Start-Up *(continued)*

FOR YOUR SAFETY READ BEFORE OPERATING/POUR VOTRE SÉCURITÉ LISEZ AVANT DE METTRE EN MARCHÉ

WARNING: If you do not follow these instructions exactly, a fire or explosion may result causing property damage, personal injury or loss of life.

AVERTISSEMENT: Quiconque ne respecte pas à la lettre les instructions dans la présente notice risque de déclencher un incendie ou une explosion entraînant des dommages, des blessures ou la mort.

- A. This appliance is equipped with an ignition device which automatically lights the pilot. Do not try to light the pilot by hand.
- B. **BEFORE OPERATING** smell all around the appliance area for gas. Be sure to smell next to the floor because some gas is heavier than air and will settle on the floor.
- WHAT TO DO IF YOU SMELL GAS:**
- Do not try to light any appliance.
 - Do not touch any electric switch; do not use any phone in your building.
 - Immediately call your gas supplier from a neighbor's phone. Follow the gas supplier's instructions.
 - If you cannot reach your gas supplier, call the fire department.
- C. Use only your hand to push in or turn the gas control knob. Never use tools. If the knob will not push in or turn by hand, don't try to repair it, call a qualified service technician. Force or attempted repair may result in a fire or explosion.
- D. Do not use this appliance if any part has been under water. Immediately call a qualified service technician to inspect the appliance and to replace any part of the control system and any gas control which has been under water.

- A. Cet appareil est muni d'un dispositif d'allumage qui allume automatiquement la veilleuse. Ne tentez pas d'allumer la veilleuse manuellement.
- B. **AVANT DE FAIRE FONCTIONNER** renifllez tout autour de l'appareil pour déceler une odeur de gaz. Renifllez près du plancher, car certains gaz sont plus lourds que l'air et peuvent s'accumuler au niveau du sol.
- QUE FAIRE SI VOUS SENTEZ UNE ODEUR DE GAZ:**
- Ne pas tenter d'allumer d'appareil.
 - Ne touchez à aucun interrupteur ; ne pas vous servir des téléphones se trouvant dans le bâtiment.
 - Appelez immédiatement votre fournisseur de gaz depuis un voisin. Suivez les instructions du fournisseur.
 - Si vous ne pouvez rejoindre le fournisseur, appelez le service des incendies.
- C. Ne poussez ou tournez la manette d'admission du gaz qu'à la main ; ne jamais utiliser d'outil. Si la manette reste coincée, ne tentez pas de la réparer ; appelez un technicien qualifié. Le fait de forcer la manette ou de la réparer peut déclencher une explosion ou un incendie.
- D. N'utilisez pas cet appareil s'il a été plongé dans l'eau, même partiellement. Faites inspecter l'appareil par un technicien qualifié et remplacez toute partie du système de contrôle et toute commande qui ont été plongés dans l'eau.

OPERATING INSTRUCTIONS/INSTRUCTIONS DE MISE EN MARCHÉ

1. STOP! Read safety information above on this label.
2. Set the thermostat to lowest setting.
3. Turn off all electric power to the appliance.
4. This appliance is equipped with an ignition device which automatically lights the burner. Do not try to light the burner by hand.
5. Remove front door.
6. Locate manual shut-off valve and both gas control valves at end of gas supply pipe going into boiler.
7. Rotate handle on manual shut-off valve clockwise ↻ from "ON" position to "OFF" position.
8. Rotate gas control knob on BOTH gas valves clockwise ↻ from "ON" position to "OFF" position.
9. Wait five (5) minutes to clear out any gas. Then smell for gas, including near the floor. If you smell gas, STOP! Follow "B" in the safety information above on this label. If you don't smell gas, go to the next step.
10. Rotate gas control knob on BOTH gas valves counterclockwise ↻ from "OFF" position to "ON" position. Do Not Force.
11. Rotate handle on manual shut-off valve counterclockwise ↻ from "OFF" position to "ON" position. Do Not Force.
12. Replace front door.
13. Turn on all electric power to the appliance.
14. Set thermostat to desired setting.
15. If the appliance will not operate, follow the instructions "To Turn Off Gas To Appliance" and call your service technician or gas supplier.

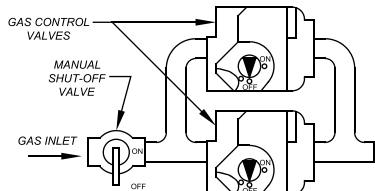

1. ARRÊTEZ ! Lisez les instructions de sécurité sur la portion supérieure de cette étiquette.
2. Réglez le thermostat à la température la plus basse.
3. Coupez l'alimentation électrique de l'appareil.
4. Cet appareil est muni d'un dispositif d'allumage qui allume automatiquement la veilleuse. Ne tentez pas d'allumer la veilleuse manuellement.
5. Enlevez la porte de devant.
6. Placer le robinet d'arrêt et les deux valves de contrôle de gaz à la fin de le tuyau d'alimentation de gaz entrant dans la chaudière.
7. Tourner la poignée manuelle robinet sens horaire ↻ de ON position à OFF position.
8. Tourner le bouton de commande de gaz sur les deux robinets de gaz sens horaire ↻ de ON position à OFF position.
9. Attendre cinq (5) minutes pour laisser échapper tout le gaz. Renifllez tout autour de l'appareil, y compris près du plancher, pour déceler une odeur de gaz. Si vous sentez une odeur de gaz, ARRÊTEZ ! Passez à l'étape B des instructions de sécurité sur la portion supérieure de cette étiquette. S'il n'y a pas d'odeur de gaz, passez à l'étape suivante.
10. Tourner le bouton de commande de gaz sur les deux robinets de gaz sens antihoraire ↻ de OFF position à ON position. Ne Forcez pas.
11. Tourner la manivelle sur manuel robinet sens antihoraire ↻ de OFF position à ON position. Ne Forcez pas.
12. Remplacez la porte de devant.
13. Mettez l'appareil sous tension.
14. Réglez le thermostat à la température désirée.
15. Si l'appareil ne se met pas en marche, suivez les instructions intitulées « Comment couper l'admission de gaz de l'appareil » et appelez un technicien qualifié ou le fournisseur de gaz.

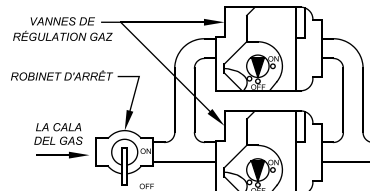

TO TURN OFF GAS TO APPLIANCE/COMMENT COUPER L'ADMISSION DE GAZ DE L'APPAREIL

1. Set the thermostat to lowest setting.
2. Turn off all electric power to the appliance if service is to be performed.
3. Remove front door.
4. Rotate handle on manual shut-off valve clockwise ↻ from "ON" position to "OFF" position. Rotate gas control knob on BOTH gas valves clockwise ↻ from "ON" position to "OFF" position.
5. Replace front door.

1. Réglez le thermostat à la température la plus basse.
2. Coupez l'alimentation électrique de l'appareil s'il faut procéder à l'entretien.
3. Enlever la porte de devant.
4. Tourner la poignée manuelle robinet sens horaire ↻ de ON position à OFF position. Tourner le bouton de commande de gaz sur les deux robinets de gaz sens horaire ↻ de ON position à OFF position.
5. Remplacez la porte de devant.

104628-01

Figure 39: Operating Instructions, Intermittent Ignition System (EI), VR8304 (IN12 only) Gas Valves

9 System Start-Up *(continued)*

Table 8: Ignition Module Terminal Cross-Reference

Ignition Module Terminal Designation	Wiring Ladder Diagram Terminal Number
MV	1
MV/PV	2
PV	3
GND	4
24V (GND)	5
24V	6
SPARK	9



Figure 41A: Location of LED

Table 9: Green LED Status Codes

Green LED Flash Code ^a	Indicates	Next System Action	Recommended Service Action
OFF	No "Call for Heat"	N/A	None
Flash Fast	Power up - internal check	N/A	None
Heartbeat	Normal startup - ignition sequence started (including prepurge)	N/A	None
4 Seconds ON then "x" flashes	Device in run mode. "x" = flame current to the nearest μ A.	N/A	None
2	5 minute Retry Delay - Pilot flame not detected during trial for ignition	Initiate new trial for ignition after retry delay completed.	If system fails to light on next trial for ignition check gas supply, pilot burner, spark and flame sense wiring, flame rod contamination or out of position, burner ground connection.
3	Recycle - Flame failed during run	Initiate new trial for ignition. Flash code will remain through the ignition trial until flame is proved.	If system fails to light on next trial for ignition, check gas supply, pilot burner, flame sense wiring, contamination of flame rod, burner ground connection.
4	Flame sensed out of sequence	If situation self corrects within 10 seconds, control returns to normal sequence. If flame out of sequence remains longer than 10 seconds, control will resume normal operation 1 hour after error is corrected.	Check for pilot flame. Replace gas valve if pilot flame present. If no pilot flame, cycle "Call for Heat." If error repeats, replace control.
6	Control Internal Error	Control remains in wait mode. When the fault corrects, control resumes normal operation.	Cycle "Call for Heat". If error repeats, replace control.
7	Flame rod shorted to ground	Control remains in wait mode. When the fault corrects, control resumes normal operation.	Check flame sense lead wire for damage or shorting. Check that flame rod is in proper position. Check flame rod ceramic for cracks, damage or tracking.
8	Low secondary voltage supply- (below 15.5 Vac)	Control remains in wait mode. When the fault corrects, control resumes normal operation.	Check transformer and AC line for proper input voltage to the control. Check with full system load on the transformer.

^aFlash Code Descriptions:

- Flash Fast: rapid blinking
- Heartbeat: Constant 1/2 second bright, 1/2 second dim cycles.
- 4 second solid on pulse followed by "x" 1 second flashes indicates flame current to the nearest μ A. This is only available in run mode.
- A single flash code number signifies that the LED flashes X times at 2Hz, remains off for two seconds, and then repeats the sequence.

9 System Start-Up *(continued)*

- b. Flame current **must be measured with pilot valve open/pilot lit but the main valve closed.**
- c. Disconnect MV lead wire from the module before measuring flame current. Trying to measure the pilot flame current in series with the wiring will not yield the accurate reading.
- d. The **minimum steady pilot flame signal must be 1 μ Amp** (microampere) **DC** (direct current).
- e. **For reliable operation** the flame current should be **2 μ Amp or greater.**
- f. To ensure **adequate flame current:**
 - i. Turn off boiler power at circuit breaker or fuse box
 - ii. Clean the flame rod with emery cloth if required
 - iii. Make sure electrical connections are clean and tight, and wiring not damaged, repair/replace as needed
 - iv. Check for igniter/sensor cracked ceramic insulator, replace if needed
 - v. Check the pilot flame. It must be blue, steady and envelop the flame sensing rod $3/8$ " to $1/2$ ".
 - vi. If needed, adjust pilot flame by turning the gas valve pilot adjustment screw

clockwise to decrease or counterclockwise to increase pilot flame. Always reinstall pilot adjustment screw cover and tighten securely upon completion to assure proper gas valve operation.

- g. Reconnect MV lead wire to the module upon satisfactory completion of pilot flame current measurement.
- h. Check the pilot burner operation/ignition sequence during ignition cycle:
 - i. Restore boiler power at circuit breaker or fuse box
 - ii. Set thermostat to call for heat
 - iii. Watch ignition sequence at burner
 - iv. If spark does not stop after pilot lights, replace ignition module
 - v. If main burners do not light or if main burners light but system locks out, check the module ground wire and gas control as described in "Honeywell Electronic Ignition Troubleshooting Guide" located in Section X "Service Instructions".

F. Check pilot burner flame and main burner flames through observation port.

1. Check pilot flame.
 - a. Continuous Ignition (Standing Pilot), Models IN10 through IN12. See Figure 42. Pilot burner produces three (3) flames. Center flame should be steady, medium hard blue enveloping $3/8$ to $1/2$ inch of thermocouple.
 - b. Electronic Ignition (EI), Models IN31 through IN12. See Figure 43. Pilot should be lit only after completing Step 3. Pilot burner produces three (3) flames. Center flame should be steady, medium hard blue enveloping $3/8$ to $1/2$ inch of sensing probe.

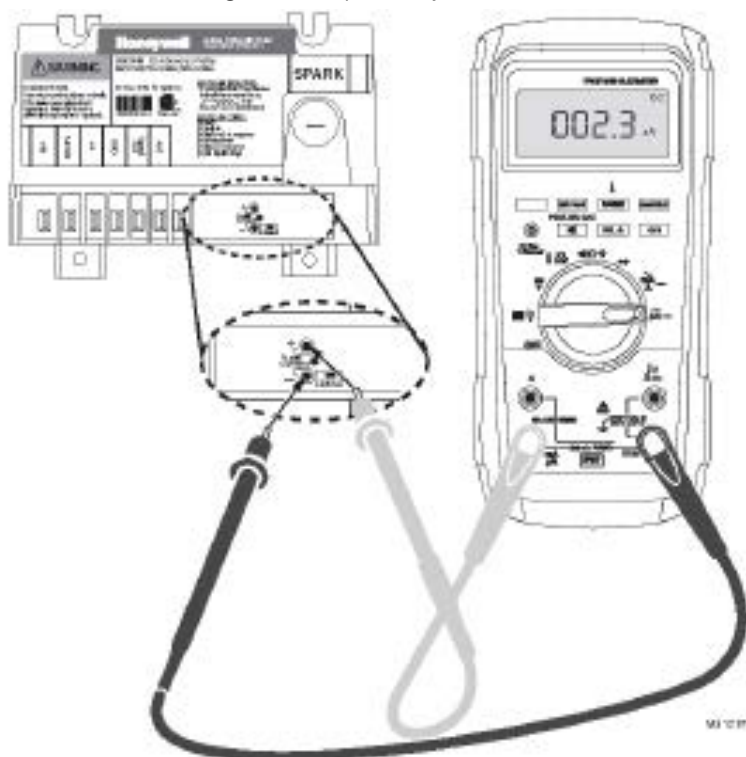

Figure 41B: Measuring Pilot Flame Current with Micro-ammeter

CAUTION

Avoid operating this boiler in an environment where saw dust, loose insulation fibers, dry wall dust, etc. are present. If boiler is operated under these conditions, the burner interior and ports must be cleaned and inspected daily to insure proper operation.

2. Adjust thermostat to highest setting.
3. Check main burner flames. See Figure 44 or 45. Flame should have clearly defined inner cones with no yellow tipping. Orange-yellow streaks caused by dust should not be confused with true yellow tipping.

9 System Start-Up *(continued)*

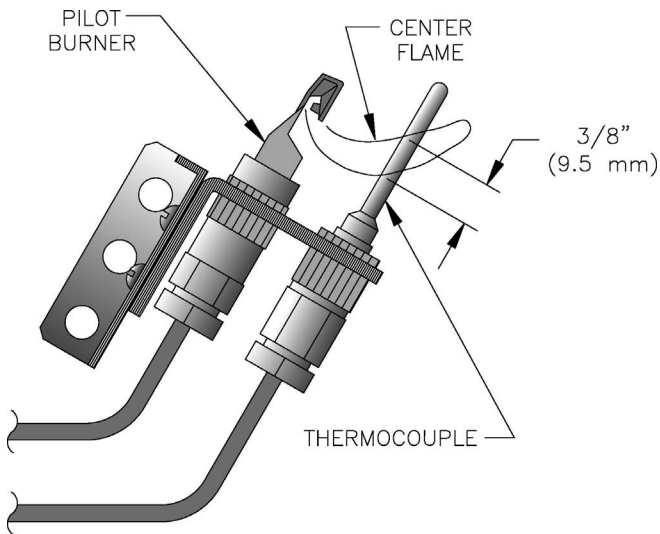

Figure 42: Pilot Burner Flame, Honeywell Q327

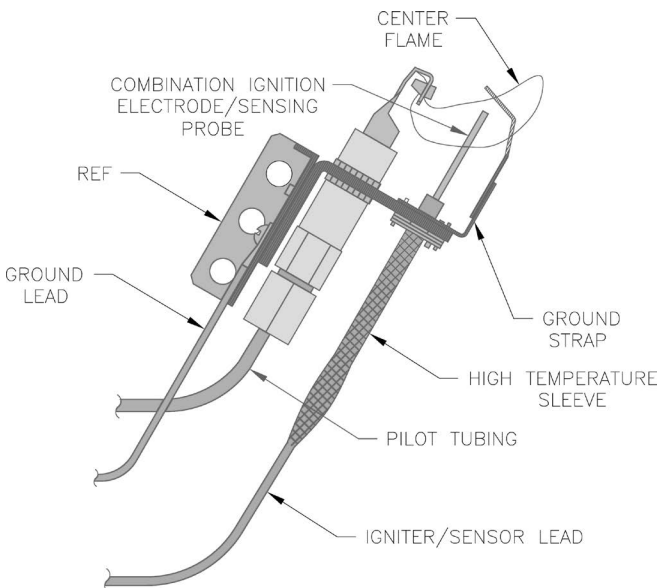

Figure 43: Typical Pilot Flame, Honeywell Q3481B

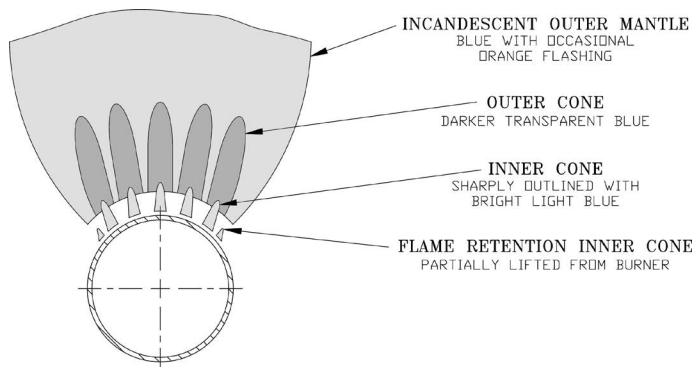

Figure 44: 40mm Main Burner Flame

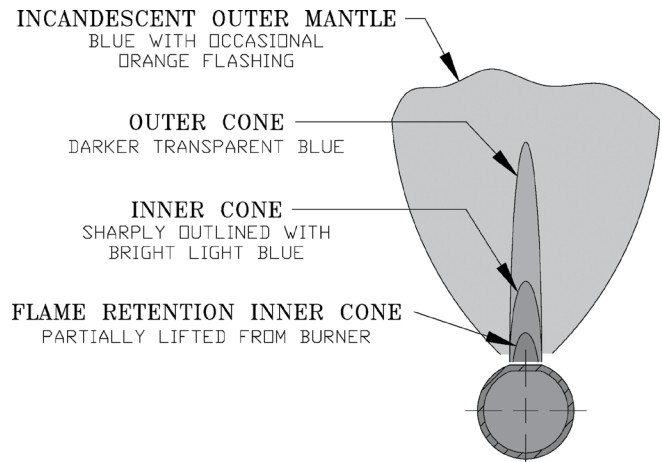

Figure 45: 1" Main Burner Flame

4. Adjust thermostat to normal setting.

G. Check thermostat operation. Raise and lower temperature setting to start and stop boiler operation.

H. Check ignition system shutoff. Gas valve should close and pilot and main burners extinguish.

1. Continuous Ignition (Standing Pilot): disconnect thermocouple from gas valve.
2. Electronic Ignition (EI): disconnect igniter/sensor cable from ignition module terminal "9".

I. Check low water cutoff.

1. Adjust thermostat to highest setting.
2. With boiler operating, open drain and slowly drain boiler.

CAUTION

Do not drain below gauge glass.

3. Main burners will extinguish when water level drops below low water cutoff. Water should still be visible in gauge glass. Verify limit, thermostat or other controls have not shut off boiler.

4. Adjust thermostat to lowest setting. Refill boiler to normal water line.

J. Check Limit.

1. Adjust thermostat to highest setting.
2. Observe pressure gauge. When pressure is indicated, adjust limit to setting below observed pressure. Main burners should extinguish.
3. Adjust limit to setting above observed reading. Main burners should reignite.

9 System Start-Up *(continued)*

WARNING

Failure to properly adjust gas input rate will result in over firing or under firing of the boiler. Improper and unsafe boiler operation may result.

4. Adjust thermostat to lowest setting. Adjust limit to desired setting.

K. Adjust gas input rate to boiler. Natural Gas.

1. Adjust thermostat to highest setting.
2. Check manifold gas pressure. Manifold pressure is listed on Rating Label.
 - a. Models IN10-IN12 with Standing Pilot and IN3I-IN11 with Electronic Ignition. Adjust gas valve pressure regulator as necessary (turn adjustment screw counterclockwise to decrease manifold pressure, or clockwise to increase manifold pressure). If pressure can not be attained, check gas valve inlet pressure. If less than minimum gas supply pressure listed on Rating Label, contact gas supplier for assistance.
 - b. Model IN12 with Electronic Only.
 - i. Turn off gas valve not having pilot control.
 - ii. On gas valve with pilot control, adjust gas valve pressure regulator to obtain required manifold pressure, or if unattainable, highest pressure without forcing adjustment screw (turn adjustment screw counterclockwise to decrease manifold pressure, or clockwise to increase manifold pressure).
 - iii. Turn on gas valve not having pilot control. Adjust gas valve pressure regulator to obtain required manifold pressure. Manifold pressure may not change during initial turns of adjustment screw.
3. Clock gas meter for at least 30 seconds. Use Table 10 to determine gas flow rate in Cubic Feet per Hour.
4. Determine Input Rate. Multiply gas flow rate by gas heating value.
5. Compare measured input rate to input rate stated on Rating Label.
 - a. Adjust gas valve pressure regulator, if necessary, to change input rate (turn counter-clockwise to decrease pressure and decrease input rate).
 - b. Contact your U.S. Boiler Company

wholesale distributor for alternate main burner orifices if outlet pressure is less than 3.2 inches water column or greater than 3.8 inches water column. Provide current orifice size, outlet gas pressure and measured input rate.

6. Recheck Main Burner Flame.
7. Return other gas-fired appliances to previous conditions of use.

L. Adjust gas input rate to boiler. LP/Propane.

1. Set thermostat to highest setting.
2. Adjust tank regulator for gas valve inlet pressure of 13.5 inches w.c. or less.
3. Gas valve has step opening regulator which initially opens to 1.4 or 2.5 inch w.c. and steps to full pressure after approximately 30 seconds. Check manifold pressure after step has occurred. Adjust gas valve pressure regulator as necessary for 10.0 inches w.c. (turn adjustment screw counterclockwise to decrease manifold pressure, or clockwise to increase manifold pressure). If 10.0 inches w.c. can not be attained, check gas valve inlet pressure. If less than 11.0 inches w.c., contact gas supplier for assistance.

M. Clean Heating System. A local qualified water treatment chemical specialist is a suggested source for recommendations regarding appropriate chemical compounds and concentrations which are compatible with local environmental regulations.

1. Oil from new piping connections and sediment in existing piping must be removed from system to prevent unsteady water line and carry-over of entrained water into supply main.
 - a. Fill boiler to normal waterline.
 - b. Follow LIGHTING OR OPERATING INSTRUCTIONS to place boiler in operation. See Figure 38, 39 or 40.
 - c. Operate boiler with steam in entire system for several days to bring system oil and dirt back to boiler.
 - d. Drain condensate from drain valve in wet return. Operate boiler until condensate runs clean.
2. Boil-out boiler.
 - a. Follow instructions TO TURN OFF GAS TO APPLIANCE. See Figure 38, 39 or 40.
 - b. Run 1-1/4 NPT pipe from Skimming Tapping "L" to open drain. Do not install shut-off valve or other restriction. See Figures 1 & 21.
 - c. Fill boiler to top of gauge glass.

9 System Start-Up *(continued)*

Table 10: Input Rate

Seconds for One Revolution	Size of Gas Meter Dial			
	One-Half Cu. Ft.	One Cu. Ft.	Two Cu. Ft.	Five Cu. Ft.
30	60	120	240	600
32	56	113	225	563
34	53	106	212	529
36	50	100	200	500
38	47	95	189	474
40	45	90	180	450
42	43	86	172	430
44	41	82	164	410
46	39	78	157	391
48	37	75	150	375
50	36	72	144	360
52	35	69	138	346
54	33	67	133	333
56	32	64	129	321
58	31	62	124	310
60	30	60	120	300
62	29	58	116	290
64	29	56	112	281
66	29	54	109	273
68	28	53	106	265
70	26	51	103	257
72	25	50	100	250
74	24	48	97	243
76	24	47	95	237
78	23	46	92	231
80	22	45	90	225

- d. Remove safety valve.
- e. Pour recommended boil-out compound into boiler through safety valve opening.
- f. Reinstall safety valve in Tapping "E" with spindle in vertical position. See Figures 1 and 21.
- g. Follow LIGHTING OR OPERATING INSTRUCTIONS to place boiler in operation. See Figure 38, 39 or 40. Boil water for approximately 5 hours without producing steam.
- h. Open boiler fill shut-off valve to produce steady trickle of water from skimming pipe. Continue boil-out for several hours until surface skimming water runs clear.

- i. Follow instructions TO TURN OFF GAS TO APPLIANCE. See Figure 38, 39 or 40. Drain boiler and system piping.
 - j. Remove drain valve. Thoroughly wash boiler water passages with high pressure spray through drain valve tapping.
 - k. Fill boiler to normal waterline. If water in gauge glass is not clear, repeat procedure starting at step b.
 - l. Remove skimming pipe. Install 1-1/4 NPT plug in Tapping "L". See Figure 2.
3. Add Boiler Water Treatment.
 - a. Remove safety valve.
 - b. Pour recommended compound into boiler through safety valve opening.
 - c. Reinstall safety valve in Tapping "E" with spindle in vertical position. See Figures 1 and 2.
 - d. Follow LIGHTING OR OPERATING INSTRUCTIONS to place boiler in operation. See Figure 38, 39 or 40.
 - e. Boil water or heat water to 180°F.
 4. If unsteady water line, foaming or priming persist:
 - a. Follow LIGHTING OR OPERATING INSTRUCTIONS to place boiler in operation. See Figure 38, 39 or 40.
 - b. Install gate valve (shut-off valve) in Hartford Loop. Install drain valves in return main and at boiler. See Figure 21.
 - c. Connect hoses from drain valves to floor drain. Close gate valve in Hartford Loop. Open drain valve in return main.
 - d. Fill boiler to normal water line. Follow LIGHTING OR OPERATING INSTRUCTIONS to place boiler in operation. See Figure 38, 39 or 40.
 - e. Operate boiler for at least 30 minutes after condensate begins to run hot. Follow instructions TO TURN OFF GAS TO APPLIANCE. See Figure 38, 39 or 40.
 - f. Close all radiator valves. Remove all supply main air valves. Plug openings in supply main.
 - g. Drain approximately 5 gallons of boiler water into container. Mix in recommended boil-out compound.
 - h. Remove safety valve. Pour recommended compound into boiler through safety valve

9 System Start-Up *(continued)*

- opening. Reinstall safety valve in Tapping "E" with spindle in vertical position. See Figures 1 and 2.
- i. Follow LIGHTING OR OPERATING INSTRUCTIONS to place boiler in operation. See Figure 38, 39 or 40. Slowly feed water to boiler. Water will rise slowly into supply main and back through return main. Adjust flow to maintain approximately 180°F water from return main hose. Continue until water runs clear from hose for at least 30 minutes.
 - j. Turn off water to boiler. Continue to operate until excess water is removed from boiler and system (by steaming) and boiler water reaches normal waterline.
 - k. Follow instructions TO TURN OFF GAS TO APPLIANCE. See Figure 38, 39 or 40. Open all radiator valves. Reinstall all supply main air valves. Open gate valve in Hartford Loop.
 - l. Allow boiler to cool until crown sheet is no longer too hot to touch. Close drain valves at boiler and in return main. Fill boiler slowly to normal waterline.
 - m. Follow LIGHTING OR OPERATING INSTRUCTIONS to place boiler in operation. See Figure 38, 39 or 40. Allow boiler to steam for 10 minutes. Drain one quart of water from lower Gauge Glass fitting.
 - n. Drain second quart sample from lower Gauge Glass fitting. If sample is not clear, repeat cycle of draining boiler and return main and refilling boiler until sample is clear.
 - o. If after normal operation boiler water becomes dirty from additional system piping sediment returning to boiler.
 - i. Complete steps 5a through 5n.
 - ii. Complete steps 3a through 3k.
5. Test System Water Quality.
 - a. After boiler and system have been cleaned and refilled as previously described, test water quality. Add recommended chemicals to bring chlorides, hardness and pH within limits outlined in Table 11.
 - b. Boiler is now ready to be put into service.
- N. Check Damper Operation** - If boiler is equipped with vent damper, vent damper must be in open position when boiler main burners are operating. Start boiler, refer to instructions on damper to determine if damper is in full open position.
- O. Review User's Information Manual** and system operation with owner or operator.
- P. Post instructions** near boiler for reference by owner and service personnel. Maintain instructions in legible condition.

Table 11: Concentration Limits for Make-up Water & Boiler Water

Constituent	Make-up Water	Boiler Water
Chlorides	≤ 30 mg/L (ppm)	≤ 100 mg/L (ppm)
Hardness (as Ca Co ₃)	≤ 100 mg/L (ppm)	≤ 200 mg/L (ppm)
pH	7.0 ≤ pH ≤ 11.0	

10 Service Instructions

DANGER

- This boiler uses flammable gas, high voltage electricity, moving parts, and very hot water under high pressure. Assure that all gas and electric power supplies are off and that the water temperature is cool before attempting any disassembly or service. .
- Assure that all gas valves and electrical disconnect switches are off before attempting any disassembly or service.
- Do not attempt any service work if gas is present in the air in the vicinity of the boiler. Never modify, remove or tamper with any control device.

WARNING

- Failure to properly wire electrical connections to the boiler may result in serious physical harm.
- Electrical power may be from more than one source. Make sure all power is off before attempting any electrical work.
- Each boiler must be protected with a properly fused disconnect.
- Never jump out or make inoperative any safety or operating controls.

CAUTION

Label all wires prior to disconnection when servicing controls. Wiring errors can cause improper and dangerous operation.

ATTENTION. Au moment de l'entretien des commandes, étiquetez tous les fils avant de les débrancher. Les erreurs de câblage peuvent nuire au bon fonctionnement et être dangereuses.

- A. General.** Inspection and service should be conducted annually, except as noted. Turn off electrical power and gas supply while conducting service or maintenance. Follow instructions TO TURN OFF GAS TO APPLIANCE. See Figures 38, 39, or 40.

B. Maintenance of Low Water Cutoff

1. McDonnell & Miller PSE-802 or Hydrolevel CycleGard CG400 Probe Style Only.
 - a. Drain boiler to point below Tapping 'K'. See Figure 2.
 - b. Disconnect wire(s) connecting control and probe.
 - c. Remove control from probe.
 - d. Unscrew probe from Tapping 'K'. Inspect for scale and sediment buildup.
 - e. Remove light deposits with damp cloth soaked with vinegar.
 - f. Remove stubborn deposits using diluted phosphoric acid (H_2PO_4) solution, 3 parts water to 1 part phosphoric acid. Normal operation will occur with up to 0.2 inch of contamination. If scale or contamination exceeds 0.2 inches, clean probe more frequently.

DANGER

Assure that the boiler is at zero pressure before removing the LWCO probe. Do not rely on the pressure gauge to indicate that the boiler is at zero pressure. Open the safety valve to relieve all internal pressure prior to proceeding. Safety valve discharge piping must be piped such that the potential for burns is eliminated.

- g. Clean Tapping 'K' to remove old pipe dope and other foreign matter.
 - h. Apply moderate amount of good quality pipe dope to probe threads, leaving two end threads bare. Install probe in Tapping 'K'. Mount control on probe. Attach wire(s) between control and probe.
 - i. Fill boiler to normal waterline. Add water treatment as needed.
2. McDonnell & Miller 67 Float Style Only.
 - a. Weekly (or more frequently if necessary). Open blow-off valve to flush sediment chamber. Follow instructions on Blow-Down Card affixed to Jacket adjacent to low water cutoff.
 - b. Annually. Dismantle to extent necessary to remove obstructions and insure proper function of working parts.
 - i. Inspect connecting lines to boiler for accumulation of mud and scale. Clean as necessary.
 - ii. Examine wiring for brittle or worn insulation and clean electrical contact.
 - iii. Inspect solder joints on bellows and

10 Service Instructions *(continued)*

Important Product Safety Information: Refractory Ceramic Fiber Product

WARNING

Some boiler components use materials that contain refractory ceramic fibers (RCF). RCF has been classified as a possible human carcinogen. When exposed to elevated temperatures, RCF may change into crystalline silica, a known carcinogen. When disturbed as a result of servicing or repair, these substances become airborne and, if inhaled, may be hazardous to your health. Avoid breathing RCF particulates and dust.

Precautionary Measures:

- Do not handle RCF parts or attempt any service or repair work involving RCF without wearing the following protective gear:
 1. A properly fitting National Institute for Occupational Safety and Health (NIOSH)-certified air-purifying respirator with a filter efficiency of at least 95%. Respirator should also include a full facepiece when handling used RCF. Other types of respirators may be required depending on site conditions. Current NIOSH recommendations may be found on the NIOSH website <http://www.cdc.gov/niosh/homepage.html>. NIOSH-approved manufacturers, respirators and associated user instructions are listed on the NIOSH website.
 2. Long sleeved, loose fitting clothing that is sufficiently tight around potential entry points for RCF dust.
 3. Gloves.
 4. Eye protection, such as goggles, safety glasses with side shields, or full facepiece.
- Take steps to assure adequate ventilation.
- Handle RCF carefully to minimize airborne dust. Use hand tools whenever possible.
- Dampen used RCF with light water spray prior to removal to prevent airborne dust.
- Do not use compressed air or dry sweeping for clean-up. Frequently clean work area with a vacuum or by wet sweeping to minimize debris accumulation.
- Vacuum work clothes before leaving work area. Wash work clothes separately from other laundry and rinse washing machine after use to avoid contaminating other clothes.
- Wash all exposed body areas gently with soap and water after contact.
- Discard used RCF components by sealing in an airtight plastic bag or container. Refer to local, regional, state or provincial regulations to identify applicable disposal requirements.

First Aid Procedures:

- Eye contact: Flush with water for at least 15 minutes. Do not rub eyes. Seek immediate medical attention if irritation persists.
- Skin contact: Wash affected area gently with soap and water. Do not rub or scratch affected skin. Seek immediate medical attention if irritation persists.
- Nose and throat contact: If these become irritated, leave the area and move to a location with clean fresh air. Drink water and blow nose. Seek immediate medical attention if symptoms persist.

10 Service Instructions *(continued)*

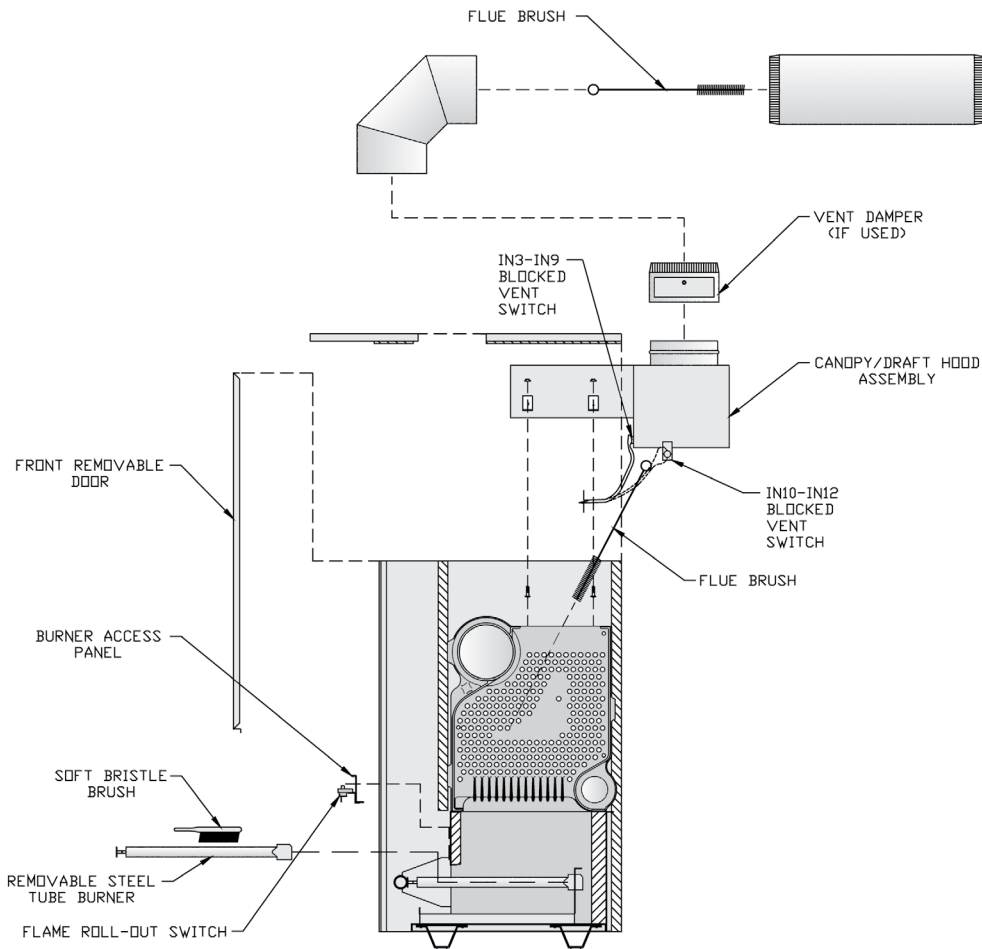

Figure 46: Boiler Flueway Cleaning

float. Check float for evidence of collapse. Check mercury bulb (where applicable) for mercury separation or discoloration. Do not attempt to repair mechanisms in field. Complete replacement mechanisms, including gaskets and instructions, are available from low water cutoff manufacturer.

- c. Five (5) Years or 100,000 switch cycles.
Replace switch and float mechanisms.

C. Water Feeder and Additional Low Water Cutoff.

Refer to manufacturer's instructions.

D. Vent System. Check annually for:

1. obstructions
2. accumulations of soot
3. deterioration of vent pipe or vent accessories due to condensation or other reasons
4. proper support—no sags, particularly in horizontal runs
5. tightness of joints. Remove all accumulations of soot with wire brush and vacuum

Remove all obstructions. Replace all deteriorated

parts and support properly. Seal all joints.

E. Clean Boiler Flueways.

1. Shut down gas boiler in accordance with lighting/operating instructions attached to inside of Front Removable Door. See Figure 35.
2. Remove Burner Access Panel and Burners. See Paragraph F. Clean Burners if necessary.
3. Remove Jacket Top Panels.
4. Remove Canopy from top of boiler.
5. Thoroughly clean the flueways with flue brush. See Figure 46.
6. Clean boiler heating surface accessible from combustion chamber with straight handle wire brush. Reinstall burners and connect gas train. See Paragraphs F & G.
7. Place boiler in operation in accordance with Lighting or Operating instructions. Test gas line for leaks in accordance with Section VI: Gas Piping, Paragraph C.

10 Service Instructions *(continued)*

- Replace Jacket Front Removable Door.

CAUTION

When necessary to remove burners, be sure to reinstall them in the original manner by engaging the orifice and locating hole in the rear of the burner tray. Burners must be aligned with the burner manifold.

- F. Remove Burners** for cleaning, changing orifice plugs, or repairs.
- Turn off electric service to boiler.
 - Turn off gas supply to boiler.
 - Remove jacket front panel.
 - Disconnect pilot tubing at gas valve.
 - Disconnect thermocouple tubing at gas valve (Continuous Ignition only). Disconnect igniter/sensor cable and ground wire at ignition module Intermittent Ignition (EI) only. Disconnect flame roll-out switch wires.
 - Remove burner access panel.
 - Mark location of pilot main burner on manifold.
 - Hold burner on throat. Lift slightly to clear orifice. Pull burner from combustion chamber. See Figure 10. Pilot main burner can only be removed by lifting at 45° angle after adjacent burner to right is removed (1" burners only).
 - Check burners to be sure they do not contain foreign matter or restrictions. Clean burners with a soft bristle brush, blow any dirt out with compressed air or use a vacuum cleaner. See Figure 46.
- G. Remove Pilot Assembly** for Servicing. Remove machine screw(s) holding pilot burner to pilot bracket, after first removing burner with pilot assembly as described in Paragraph F, number 8 above.
- Use a round wire gauge to check spark gap.
 - Spark gap should be 0.125" for optimum performance.
- H. Install Burners** by reversing procedures used to remove burner. Main burners must be in slots in rear of burner tray and seated on main burner orifices. Reconnect pilot gas supply, and thermocouple lead (continuous ignition) or igniter/sensor/ground. See Table 12 for Pilot Burner location.
- I. Lubrication.** Manufacturers Instruction should be followed on all parts installed on boiler requiring lubrication. This includes:

Table 12: Pilot Burner Location

Boiler Size	Pilot Located Between Burners*	
	1 inch	40mm
IN3I	1 & 2	1 & 2
IN4I	2 & 3	2 & 3
IN5I	3 & 4	2 & 3
IN6I	4 & 5	3 & 4
IN7I	6 & 7	3 & 4
IN8I	7 & 8	4 & 5
IN9I	8 & 9	4 & 5
IN10	9 & 10	---
IN11	11 & 12	---
IN12	12 & 13	---

* Burners numbered left to right as viewed from front of boiler.

- Type of lubricant to be used.
- Frequency of lubrication.
- Points to lubricate.

J. Check operation. Follow Paragraphs B through L and Paragraph O from Section IX: System Start-up.

K. Conversion Kits. Follow all instructions provided with kits. Note that Rating Label provided in kit must be used. Apply over or beside original Rating Label allowing the original Serial Number to remain visible.

L. Tankless Heater.

- Flushing of Heater. All water contains some sediment which settles on inside of coil. Consequently, heater should be periodically backwashed. See Figure 25. Allow water at city pressure to run into hosebib A, through heater, and out hosebib B until discharge is clear. The tees in which the hosebibs are located should be the same size as heater connections to minimize pressure drop.
- Adjust and maintain mixing valve (tempering valve) in accordance with manufacturer's instructions.

10 Service Instructions *(continued)*

M. Excessive Make-Up Water

CAUTION

IF, DURING NORMAL OPERATION, IT IS NECESSARY TO ADD MORE WATER THAN INDICATED BELOW, CONSULT A QUALIFIED SERVICE TECHNICIAN TO CHECK YOUR SYSTEM FOR LEAKS.

Model No.	Gallons Per Month	Gallons Per Year
IN3I	0.1	1
IN4I	0.1	1
IN5I	0.2	2
IN6I	0.2	2
IN7I	0.2	3
IN8I	0.2	3
IN9I	0.3	3
IN10	0.3	4
IN11	0.3	4
IN12	0.4	4

A leaky system will increase the volume of make-up water supplied to the boiler, which can significantly shorten the life of the boiler. Entrained in make-up water are dissolved minerals, salts, and oxygen. When the fresh, cool make-up water is heated in the boiler, the minerals fall out as sediment, the salts coat the inside of the boiler, and the oxygen escapes as a gas. The accumulation of sediment eventually isolates the water from contacting the cast iron. When this happens the cast iron in that area gets extremely hot and eventually cracks. The presence of free oxygen or chloride slats in the boiler corrodes the cast iron from the inside. More make-up water and higher concentrations of contaminants damage the boiler sooner. **Our warranty does not cover corrosion and sediment-related damage.**

Clearly it is in everyone's best interest to prevent this type of failure. You can do your part by ensuring that your system is leak-free, keeping leakage to less than 2 percent of the total water volume each month.

- N. Remove** obstructions to flow of combustion and ventilation air.

Honeywell Electronic Ignition Trouble Shooting Guide

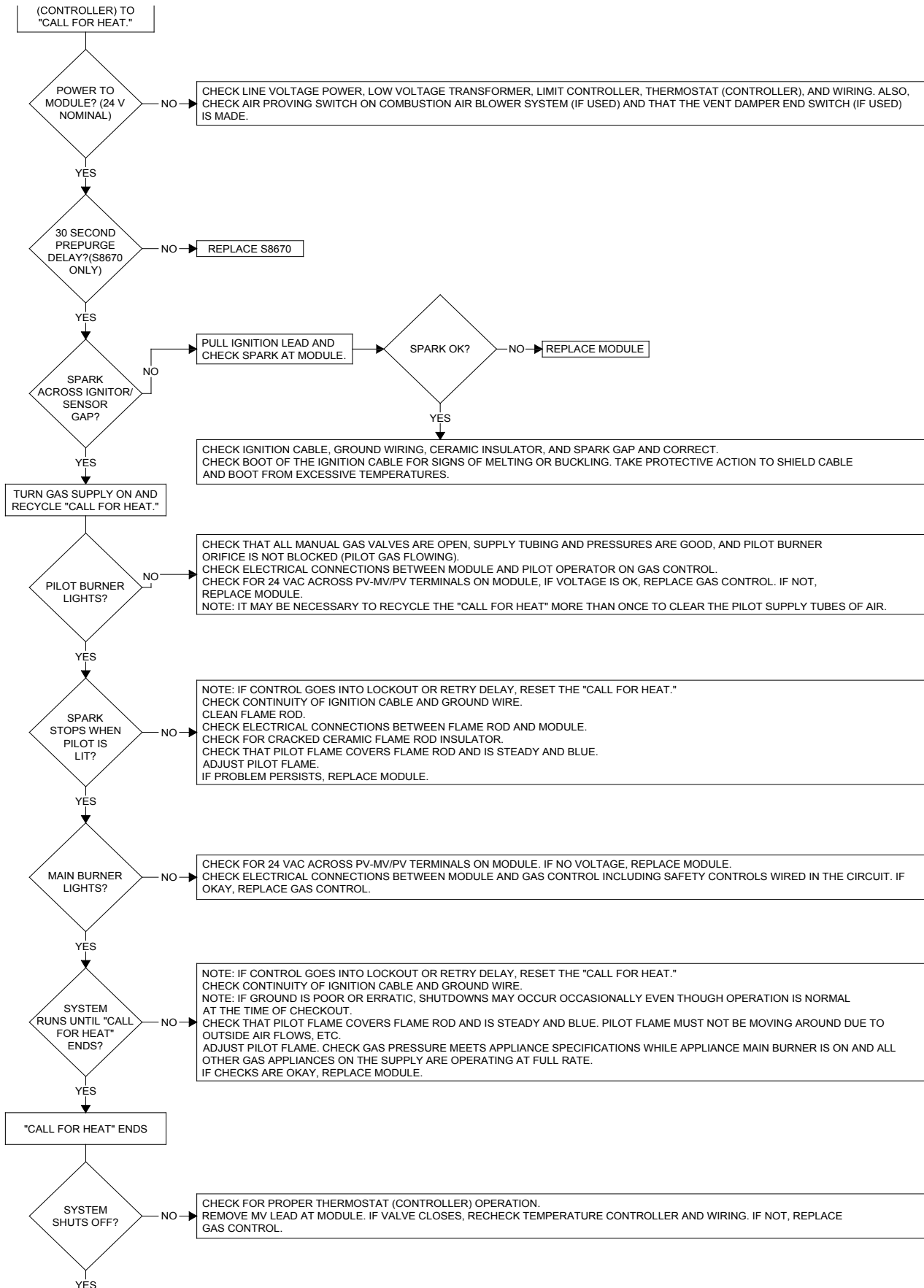

11 Service Parts

All Independence® Repair Parts may be obtained through your local U.S. Boiler Company Wholesale distributor. Should you require assistance in locating a U.S. Boiler Company Distributor in your area, or have questions regarding the availability of U.S. Boiler Company products or repair parts, please contact U.S. Boiler Company Customer Service at (717) 481-8400 or Fax (717) 481-8408.

Key No.	Description	Part No.	Quantity									
			IN3I	IN4I	IN5I	IN6I	IN7I	IN8I	IN9I	IN10	IN11	IN12
1. Section Assembly (Complete)												
1	No Tankless Opening	617100321	1	---	---	---	---	---	---	---	---	---
		617100421	---	1	---	---	---	---	---	---	---	---
		617100521	---	---	1	---	---	---	---	---	---	---
		617100621	---	---	---	1	---	---	---	---	---	---
		617100721	---	---	---	---	1	---	---	---	---	---
		617100821	---	---	---	---	---	1	---	---	---	---
		617100921	---	---	---	---	---	---	1	---	---	---
		617101021	---	---	---	---	---	---	---	1	---	---
		617101121	---	---	---	---	---	---	---	---	1	---
	617101221	---	---	---	---	---	---	---	---	---	1	
	With Tankless Opening	61710031	1	---	---	---	---	---	---	---	---	---
		61710041	---	1	---	---	---	---	---	---	---	---
		61710051	---	---	1	---	---	---	---	---	---	---
		61710061	---	---	---	1	---	---	---	---	---	---
		61710071	---	---	---	---	1	---	---	---	---	---
		61710081	---	---	---	---	---	1	---	---	---	---
		61710091	---	---	---	---	---	---	1	---	---	---
		61710101	---	---	---	---	---	---	---	1	---	---
61710111		---	---	---	---	---	---	---	---	1	---	
91710121	---	---	---	---	---	---	---	---	---	1		

11 Service Parts *(continued)*

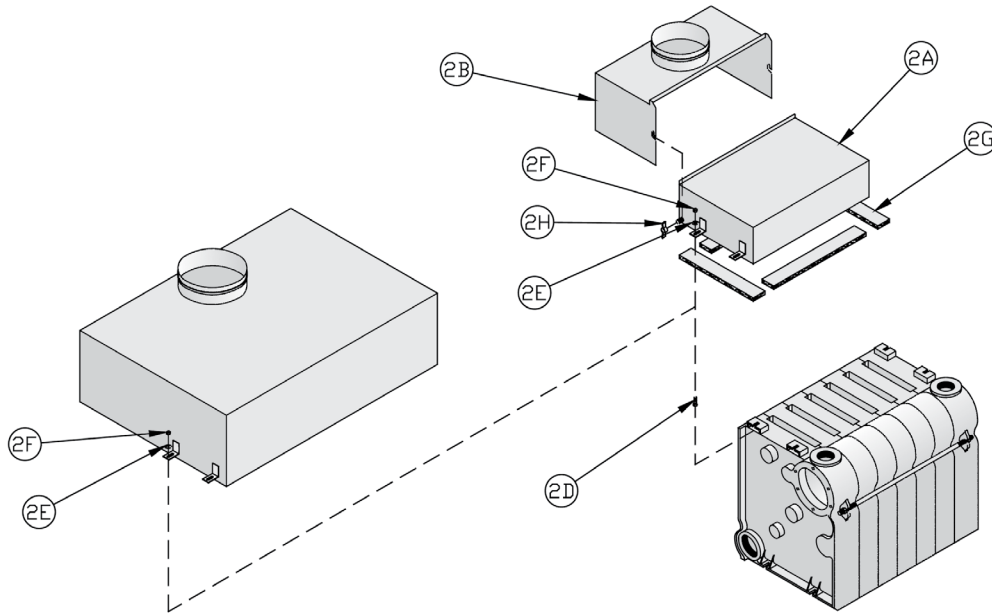

Key No.	Description	Part No.	Quantity									
			IN3I	IN4I	IN5I	IN6I	IN7I	IN8I	IN9I	IN10	IN11	IN12
2. Canopy and Draft Hood Canopy/Draft Hood Parts												
2A	Canopy Assembly	6111003	1	---	---	---	---	---	---	---	---	---
		6111004	---	1	---	---	---	---	---	---	---	---
		6111005	---	---	1	---	---	---	---	---	---	---
		6111006	---	---	---	1	---	---	---	---	---	---
		6111007	---	---	---	---	1	---	---	---	---	---
		6111008	---	---	---	---	---	1	---	---	---	---
		6111009	---	---	---	---	---	---	1	---	---	---
2B	Drafthood Carton Assembly	61110033	1	---	---	---	---	---	---	---	---	---
		61110043	---	1	---	---	---	---	---	---	---	---
		61110053	---	---	1	---	---	---	---	---	---	---
		61110063	---	---	---	1	---	---	---	---	---	---
		61110073	---	---	---	---	1	---	---	---	---	---
		61110083	---	---	---	---	---	1	---	---	---	---
		61110093	---	---	---	---	---	---	1	---	---	---
2C	Canopy/Draft Hood Carton Assembly (complete)	61110102	---	---	---	---	---	---	---	1	---	---
		61110112	---	---	---	---	---	---	---	---	1	---
		61110122	---	---	---	---	---	---	---	---	---	1
2D	Carriage Bolt, 1/4 -20 x 1"	80860115	4	4	4	4	4	4	4	4	4	4
2E	Flat Washer, 1/4"	80860603	4	4	4	4	4	4	4	4	4	4
2F	Hex Nut, 1/4 -20	80860407	4	4	4	4	4	4	4	4	4	4
2G	Gasket	6206001	1	1	1	1	1	1	1	1	1	1
2H	Wingnut, 1/4 -20	80860900	2	2	2	2	2	2	2	---	---	---

11 Service Parts *(continued)*

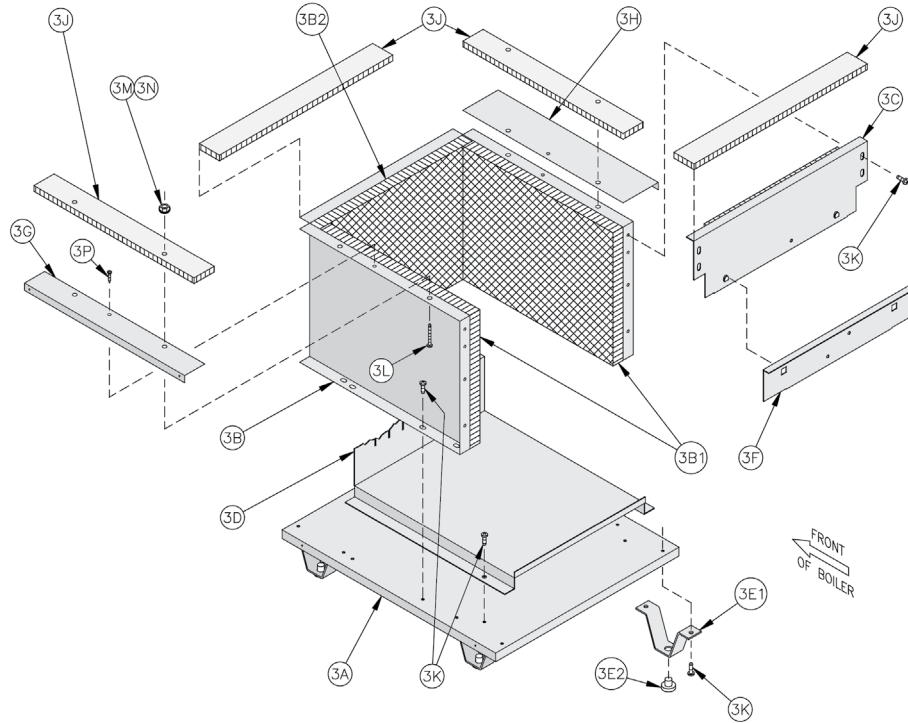

Key No.	Description	Part No.	Quantity									
			IN3I	IN4I	IN5I	IN6I	IN7I	IN8I	IN9I	IN10	IN11	IN12
3. Base Assembly												
3A	Base Tray	718600391	1	---	---	---	---	---	---	---	---	---
		718600491	---	1	---	---	---	---	---	---	---	---
		718600591	---	---	1	---	---	---	---	---	---	---
		718600691	---	---	---	1	---	---	---	---	---	---
		718600791	---	---	---	---	1	---	---	---	---	---
		718600891	---	---	---	---	---	1	---	---	---	---
		718600991	---	---	---	---	---	---	1	---	---	---
		718601091	---	---	---	---	---	---	---	1	---	---
		718601191	---	---	---	---	---	---	---	---	1	---
		718601291	---	---	---	---	---	---	---	---	1	
3B	Base Wrapper	718600311	1	---	---	---	---	---	---	---	---	---
		718600411	---	1	---	---	---	---	---	---	---	---
		718600511	---	---	1	---	---	---	---	---	---	---
		718600611	---	---	---	1	---	---	---	---	---	---
		718600711	---	---	---	---	1	---	---	---	---	---
		718600811	---	---	---	---	---	1	---	---	---	---
		718600911	---	---	---	---	---	---	1	---	---	---
		718601011	---	---	---	---	---	---	---	1	---	---
		718601111	---	---	---	---	---	---	---	---	1	---
		718601211	---	---	---	---	---	---	---	---	1	
3B1	Base End Insulation	720601	2	2	2	2	2	2	2	2	2	

11 Service Parts *(continued)*

Key No.	Description	Part No.	Quantity									
			IN3I	IN4I	IN5I	IN6I	IN7I	IN8I	IN9I	IN10I	IN11I	IN12I
3. Base Assembly (Continued)												
3B2	Base Rear Insulation	72060035	1	---	---	---	---	---	---	---	---	---
		72060045	---	1	---	---	---	---	---	---	---	---
		72060055	---	---	1	---	---	---	---	---	---	---
		72060065	---	---	---	1	---	---	---	---	---	---
		72060075	---	---	---	---	1	---	---	---	---	---
		72060085	---	---	---	---	---	1	---	---	---	---
		72060095	---	---	---	---	---	---	1	---	---	---
		72060105	---	---	---	---	---	---	---	1	---	---
		72060115	---	---	---	---	---	---	---	---	1	---
		72060126	---	---	---	---	---	---	---	---	---	1
3C	Base Front Panel Assembly	618600341	1	---	---	---	---	---	---	---	---	---
		618600441	---	1	---	---	---	---	---	---	---	---
		618600541	---	---	1	---	---	---	---	---	---	---
		618600641	---	---	---	1	---	---	---	---	---	---
		618600741	---	---	---	---	1	---	---	---	---	---
		618600841	---	---	---	---	---	1	---	---	---	---
		618600941	---	---	---	---	---	---	1	---	---	---
		618601041	---	---	---	---	---	---	---	1	---	---
		618601141	---	---	---	---	---	---	---	---	1	---
		618601241	---	---	---	---	---	---	---	---	---	1
3D	Burner Tray (1 Inch Main Burners)	718600305	1	---	---	---	---	---	---	---	---	---
		718600405	---	1	---	---	---	---	---	---	---	---
		718600505	---	---	1	---	---	---	---	---	---	---
		718600605	---	---	---	1	---	---	---	---	---	---
		718600705	---	---	---	---	1	---	---	---	---	---
		718600805	---	---	---	---	---	1	---	---	---	---
		718600905	---	---	---	---	---	---	1	---	---	---
		718601005	---	---	---	---	---	---	---	1	---	---
		718601105	---	---	---	---	---	---	---	---	1	---
		718601205	---	---	---	---	---	---	---	---	---	1
	Burner Tray (40mm Main Burners)	71806037	1	---	---	---	---	---	---	---	---	---
		71806047	---	1	---	---	---	---	---	---	---	---
		71806057	---	---	1	---	---	---	---	---	---	---
		71806067	---	---	---	1	---	---	---	---	---	---
		71806077	---	---	---	---	1	---	---	---	---	---
		718060806	---	---	---	---	---	1	---	---	---	---
718600906	---	---	---	---	---	---	1	---	---	---		
3E	Base Leg Assembly	6186001	4	4	4	4	4	4	4	4	6	6
3E1	Base Leg [Included in Key No. 3E]	71860021	4	4	4	4	4	4	4	4	6	6
3E2	Nylon Glide [Included in Key No. 3E]	8186006	4	4	4	4	4	4	4	4	6	6

11 Service Parts *(continued)*

Key No.	Description	Part No.	Quantity									
			IN3I	IN4I	IN5I	IN6I	IN7I	IN8I	IN9I	IN10	IN11	IN12
3. Base Assembly (Continued)												
3F	Burner Access Panel	718600361	1	---	---	---	---	---	---	---	---	---
		718600461	---	1	---	---	---	---	---	---	---	---
		718600561	---	---	1	---	---	---	---	---	---	---
		718600661	---	---	---	1	---	---	---	---	---	---
		718600761	---	---	---	---	1	---	---	---	---	---
		718600861	---	---	---	---	---	1	---	---	---	---
		718600961	---	---	---	---	---	---	1	---	---	---
		718601061	---	---	---	---	---	---	---	1	---	---
		718601161	---	---	---	---	---	---	---	---	1	---
		718601261	---	---	---	---	---	---	---	---	---	1
3G	Left End Jacket Attachment Bracket	7046011	1	1	1	1	1	1	1	1	1	
3H	Right End Jacket Attachment Bracket	7046012	1	1	1	1	1	1	1	1	1	
3J	Base Sealant	6206002	1	1	1	1	1	1	1	1	1	
3K	Screw, Self Tapping, Type F, Phillips Pan Head, 1/4 -20 x 1/2", Plated	80860700	16	16	16	16	17	17	17	17	21	21
3L	Screw, Self Tapping, Type F, Hex Head, 5/16 -18 x 1-1/4", Plated	80860717	4	4	4	4	4	4	4	4	4	4
3M	Washer, 5/16, USS	80860601	4	4	4	4	4	4	4	4	4	4
3N	Hex Lock Nut, 5/16 -18	80860464	4	4	4	4	4	4	4	4	4	4
3P	Screw, Sheet Metal, #8 x 1/2"	80860000	2	2	2	2	2	2	2	2	2	2

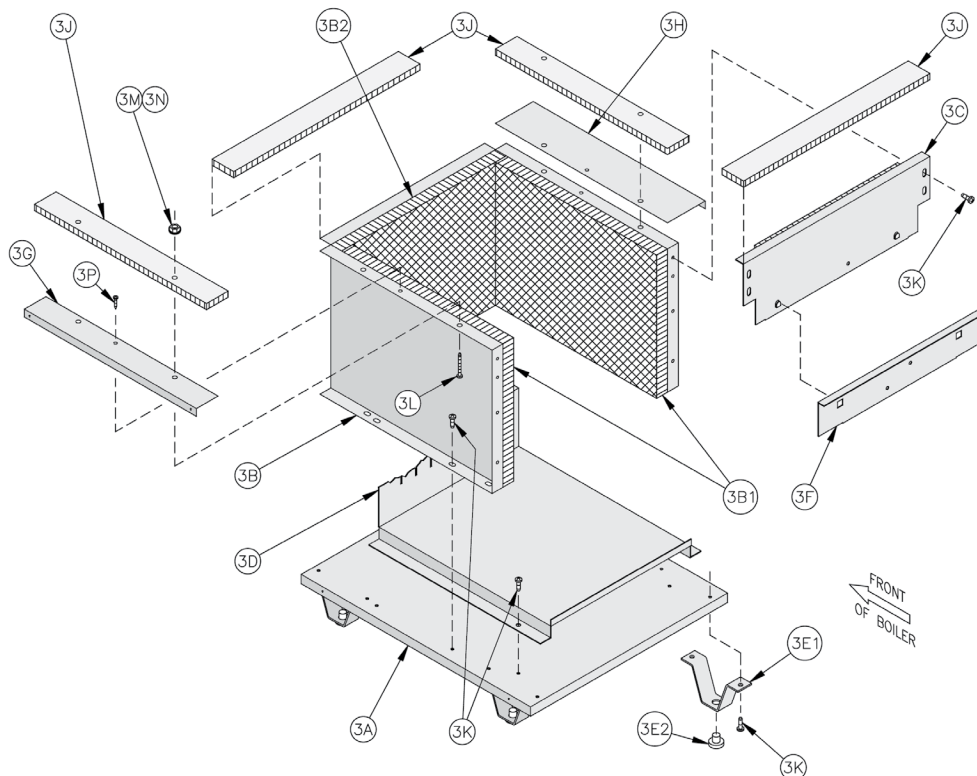

11 Service Parts *(continued)*

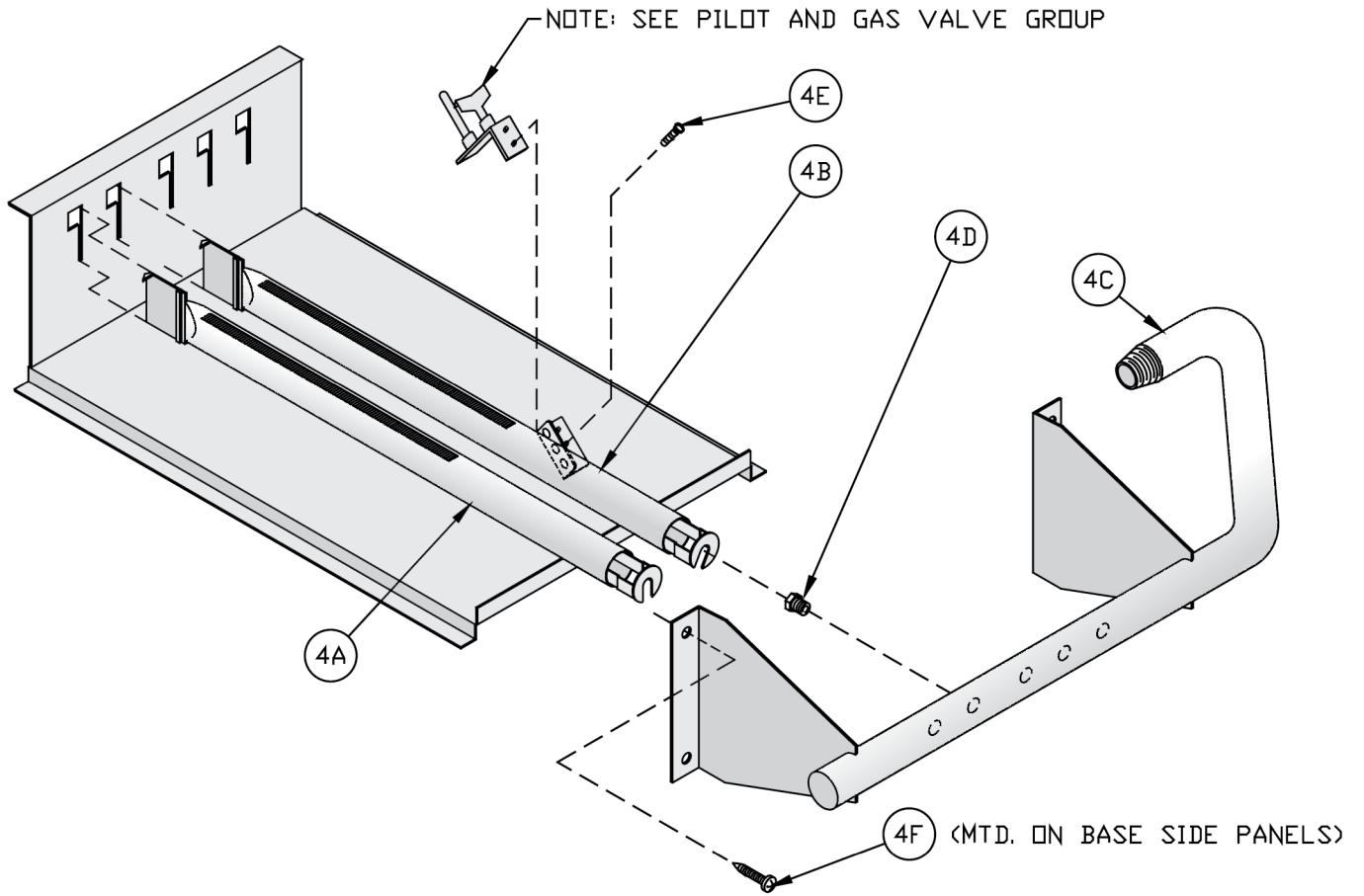

Manifold and 1" Main Burners

11 Service Parts *(continued)*

Key No.	Description	Part No.	Quantity									
			IN3I	IN4I	IN5I	IN6I	IN7I	IN8I	IN9I	IN10	IN11	IN12
4. Manifold and Main Burners (1 Inch Main Burners Only)												
4A	Main Burner	8236099	2	4	6	8	11	13	15	17	20	22
4B	Main Burner with Pilot Bracket	8236098	1	1	1	1	1	1	1	1	1	1
4C	Manifold	82260033	1	---	---	---	---	---	---	---	---	---
		82260043	---	1	---	---	---	---	---	---	---	---
		82260053	---	---	1	---	---	---	---	---	---	---
		82260063	---	---	---	1	---	---	---	---	---	---
		82260073	---	---	---	---	1	---	---	---	---	---
		82260083	---	---	---	---	---	1	---	---	---	---
		82260093	---	---	---	---	---	---	1	---	---	---
		82260103	---	---	---	---	---	---	---	1	---	---
		82260113	---	---	---	---	---	---	---	---	1	---
4D Natural Gas Only	Main Burner Orifice, #45 Pink	822711	3	5	7	9	---	---	---	---	---	---
	Main Burner Orifice, #47 White	822710	---	---	---	---	12	14	16	18	21	23
4D LP Only	Main Burner Orifice, #55 Green	822708	3	---	---	---	---	---	---	---	---	---
	Main Burner Orifice, 1.25 mm, Purple	822705	---	5	7	9	---	---	---	---	---	---
	Main Burner Orifice, 3/64", Blue	822704	---	---	---	---	12	14	16	---	---	---
4E	Screw, Machine, Slotted Round Head, 10-32 x 3/16"	80860800	2	2	2	2	2	2	2	2	2	2
4F	Screw, Self Tapping, Phillips Pan Head, 1/4 -20 x 1/2"	80860700	4	4	4	4	4	4	4	4	4	4

Note: Orifice Sizes shown for normal altitude (0-2000 feet). For High Altitude consult factory.

11 Service Parts *(continued)*

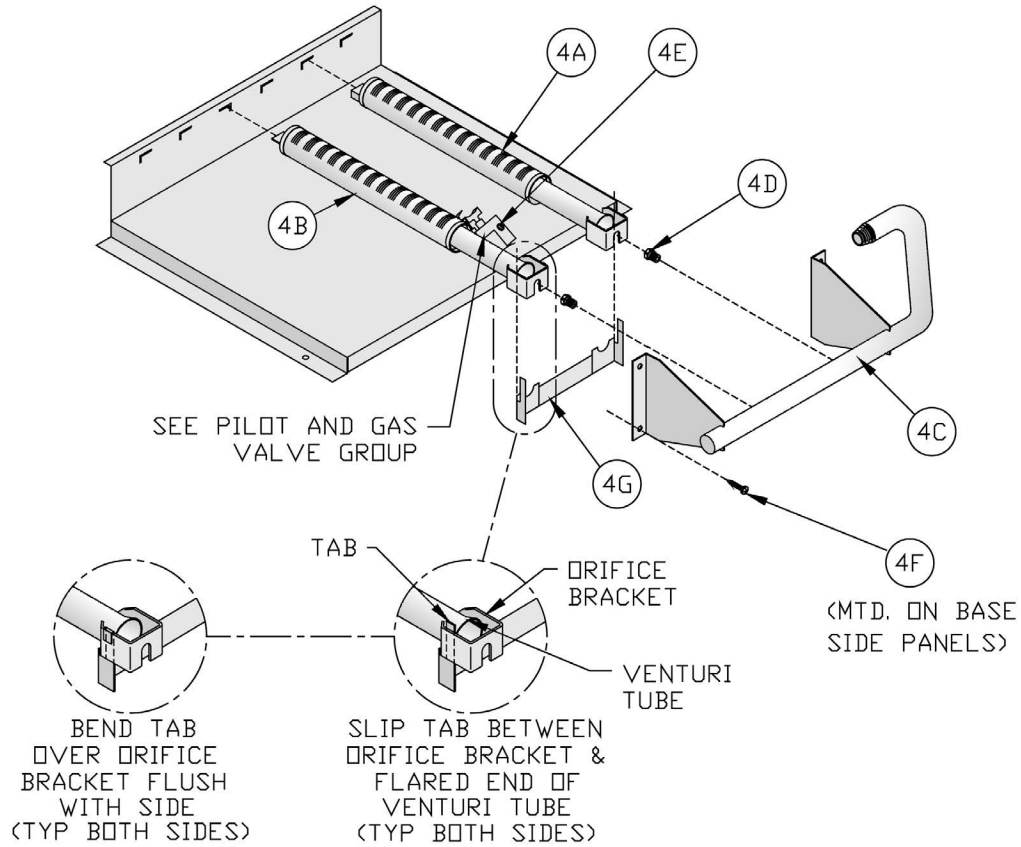

Manifold and 40mm Main Burners

Key No.	Description	Part No.	Quantity						
			IN3I	IN4I	IN5I	IN6I	IN7I	IN8I	IN9I
4. Manifold and Main Burners (40MM MAIN BURNERS ONLY)									
4A	Main Burner	8236135	1	2	3	4	5	6	7
Intermittent Ignition Only									
4B	Main Burner with 41° Pilot Bracket	8236136	1	1	1	1	1	1	1

11 Service Parts *(continued)*

Key No.	Description	Part No.	Quantity							
			IN3I	IN4I	IN5I	IN6I	IN7I	IN8I	IN9I	
4. Manifold and Main Burners (40MM MAIN BURNERS ONLY) Continued										
Natural Gas, High Altitude (2000-5000 Ft.) USA Only										
4D	Main Burner Orifice #39	822727	2	3	---	---	---	---	---	
	Main Burner Orifice #38	822720	---	---	4	5	6	7	8	
LP Gas, High Altitude (2000-5000 Ft.) USA Only										
4D	Main Burner Orifice #53	822722	2	3	4	5	6	7	8	
Natural Gas, High Altitude (5000-9000 Ft.) USA Only										
4D	Main Burner Orifice #41	822729	2	3	---	---	---	---	---	
	Main Burner Orifice #42	822728	---	---	4	5	6	7	8	
LP Gas, High Altitude (5000-9000 Ft.) USA Only										
4D	Main Burner Orifice #54	822734	2	---	---	---	---	---	---	
	Main Burner Orifice #53	822722	---	3	4	5	6	7	8	
Natural Gas, High Altitude (2000-4500 Ft.) Canada Only										
4D	Main Burner Orifice #37	822719	2	---	---	---	---	---	---	
	Main Burner Orifice #36	822771	---	3	4	5	6	7	8	
LP Gas, High Altitude (2000-4500 Ft.) Canada Only										
4D	Main Burner Orifice #52	822721	2	3	4	5	6	7	8	
4E	Screw, Machine, Slotted Round Head, #10-32 x 3/16"	80860800	2	2	2	2	2	2	2	
Natural Gas, High Altitude (2000-5000 Ft.) USA Only										
4F	Screw, Self Tapping, Phillips Pan Head, 1/4 - 20 x 1/2"	80860700	4	4	4	4	4	4	4	
4G	Injection Shield Assembly	718600362	1	---	---	---	---	---	---	
		718600462	---	1	---	---	---	---	---	
		718600562	---	---	1	---	---	---	---	
		718600662	---	---	---	1	---	---	---	
		718600762	---	---	---	---	1	---	---	
		718600862	---	---	---	---	---	1	---	
		718600962	---	---	---	---	---	---	1	
4F	Screw, Self Tapping, Phillips Pan Head, 1/4 - 20 x 1/2"	80860700	4	4	4	4	4	4	4	

11 Service Parts *(continued)*

Key No.	Description	Part No.	Quantity						
			IN3I	IN4I	IN5I	IN6I	IN7I	IN8I	IN9I
4. Manifold and Main Burners (40MM MAIN BURNERS ONLY) Continued									
Natural Gas, High Altitude (2000-5000 Ft.) USA Only									
4G	Injection Shield Assembly	718600362	1	---	---	---	---	---	---
		718600462	---	1	---	---	---	---	---
		718600562	---	---	1	---	---	---	---
		718600662	---	---	---	1	---	---	---
		718600762	---	---	---	---	1	---	---
		718600862	---	---	---	---	---	1	---
		718600962	---	---	---	---	---	---	1

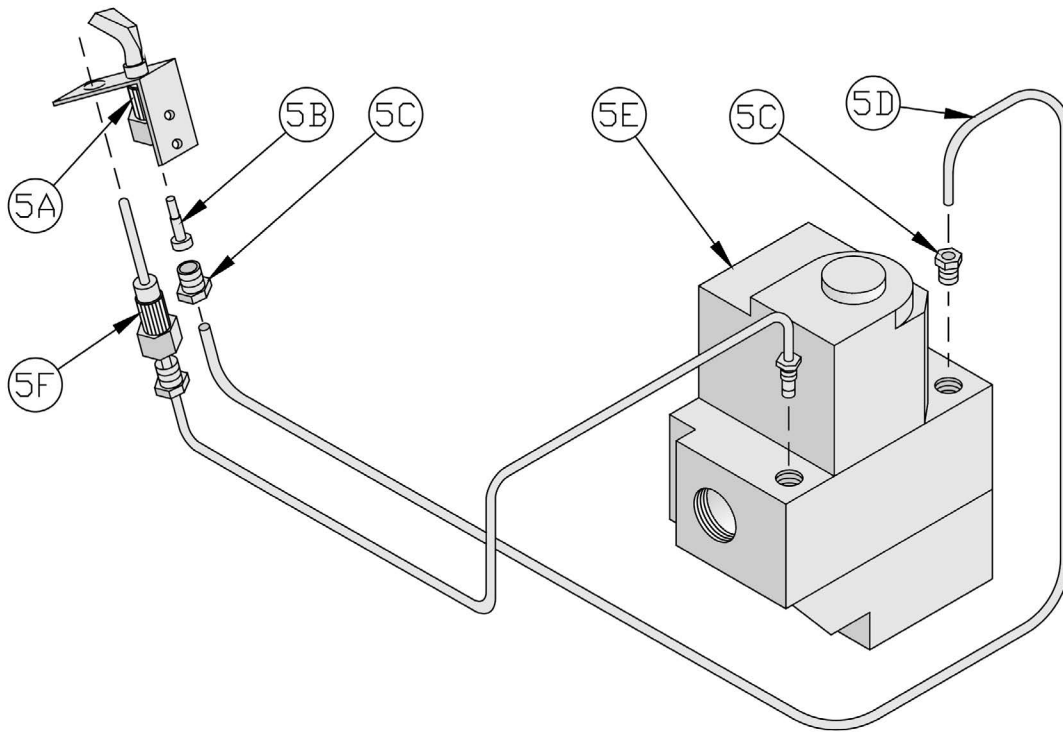

Key No.	Description	Part No.	Quantity		
			IN10	IN11	IN12
5. Pilot Burner and Gas Valve, Continuous Ignition (Standing Pilot), Natural Gas					
5A	Pilot Burner, Honeywell Q327A1006	8236022	1	1	1
5B	Pilot Orifice, Honeywell 388146AG	Included with 5A	1	1	1
5C	Compression Nut/Fitting, 1/4" OD x 1/4 C.C. (Included with 5A)	8236109	2	2	2
5D	Pilot Tubing, 1/4" OD x 40"	8236123	1	1	1
5E	Gas Valve, Robertshaw 7000ERHC-S7C	81660156	1	1	1
	Gas Valve, ITT K3A451	81660080	1	1	1
5F	Thermocouple, Honeywell Q309A	8236024	1	1	1

Note: Gas Valve specifications shown for normal altitude (0-2000 feet). For High Altitude consult factory.

11 Service Parts *(continued)*

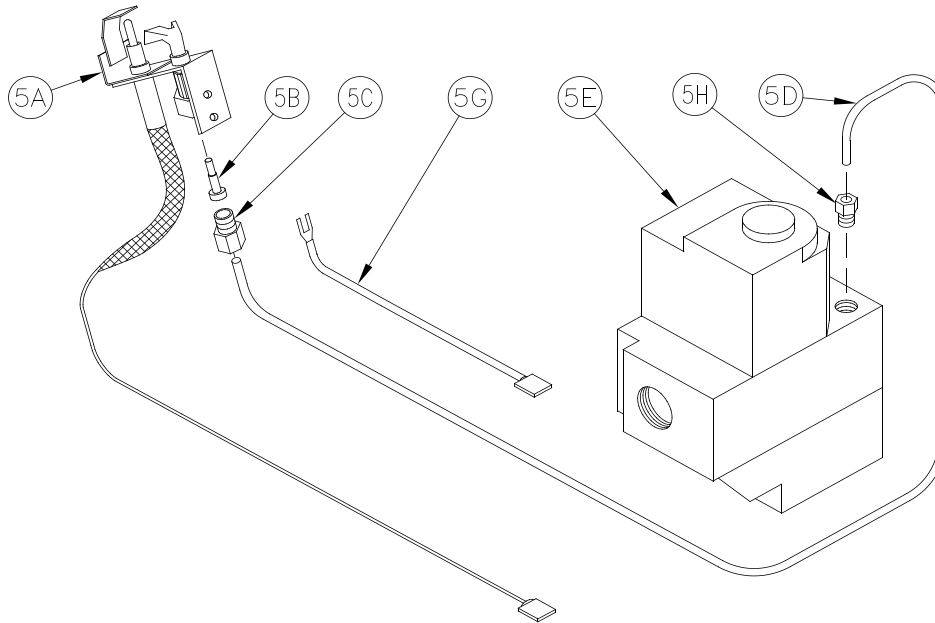

Key No.	Description	Part No.	Quantity										
			IN3I	IN4I	IN5I	IN6I	IN7I	IN8I	IN9I	IN10	IN11	IN12	
5. Pilot Burner and Gas Valve, Intermittent Ignition (EI), Natural Gas													
5A	Pilot Burner, Honeywell Q3481B1206 with Fiberglass Insulated Integral 36" Ig. Igniter/Sensor Cable	106125-01	1	1	1	1	1	1	1	1	1	1	
5B	Pilot Burner Orifice, Honeywell KF24, 0.024" dia.	Included with 5A	1	1	1	1	1	1	1	1	1	1	
5C	Compression Fitting, 7/16" Hex x 5/8" Ig., Honeywell 386449-4		1	1	1	1	1	1	1	1	1	1	
5D	Pilot Tubing, 1/4" OD x 30"	8236122	1	1	1	1	1	---	---	---	---	---	
	Pilot Tubing, 1/4" OD x 40"	8236123	---	---	---	---	---	1	1	1	1	1	
5E	Gas Valve, Honeywell VR8204C3007	81660145	1	1	1	1	---	---	---	---	---	---	
	Gas Valve, Honeywell VR8304P4306	81660161	---	---	---	---	1	1	1	1	1	2	
5F	Igniter/Sensor Cable, 36", Honeywell 394800-36	8236084	1	1	1	1	1	1	1	1	1	1	
5G	Ground Wire Assembly	6136054	1	1	1	1	1	1	1	1	1	1	
5H	Compression Fitting, 1/4" OD x 1/4" CC, Honeywell 386449-1/B	8236109	1	1	1	1	1	1	1	1	1	1	
5. Pilot Burner and Gas Valve, Intermittent Ignition (EI), LP/Propane													
5A	Pilot Burner, Honeywell Q3481B1420 with Fiberglass Insulated Integral 36" Ig. Igniter/Sensor Cable	106126-01	1	1	1	1	1	1	1	--	--	--	
5B	Pilot Burner Orifice, Honeywell KR14, 0.014" dia.	Included with 5A	1	1	1	1	1	1	1	--	--	--	
5C	Compression Fitting, 7/16" Hex x 5/8" Ig., Honeywell 386449-4		1	2	1	1	1	1	1	--	--	--	
5D	Pilot Tubing, 1/4" OD x 30"	8236122	1	1	1	1	1	---	---	--	--	--	
	Pilot Tubing, 1/4" OD x 40"	8236123	---	---	---	---	---	1	1	--	--	--	
5E	Gas Valve, Honeywell VR8204C3015	81660146	1	1	1	1	---	---	---	--	--	--	
	Gas Valve, Honeywell VR8304P4314	81660160	---	---	---	---	1	1	1	--	--	--	
5F	Igniter/Sensor Cable, 36" Honeywell 394800-36	8236084	1	1	1	1	1	1	1	--	--	--	
5G	Ground Wire Assembly	6136054	1	1	1	1	1	1	1	--	--	--	
5H	Compression Fitting, 1/4" OD x 1/4" CC, Honeywell 386449-1/B	8236109	1	1	1	1	1	1	1	--	--	--	

Note: Gas Valve specifications shown for normal altitude (0-2000 feet). For High Altitude consult factory.

11 Service Parts *(continued)*

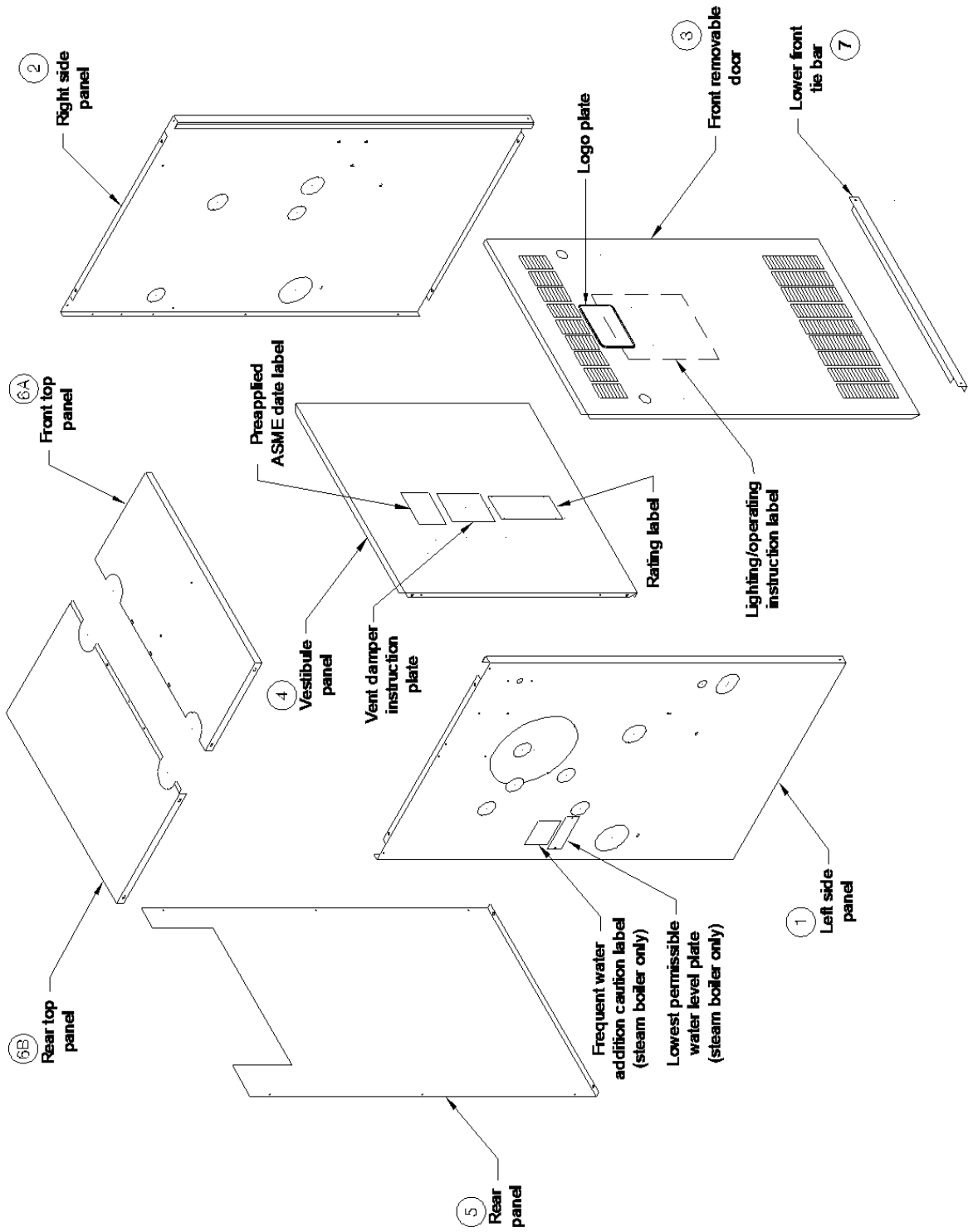

11 Service Parts *(continued)*

Key No.	Description	Part No.	Quantity										
			IN3I	IN4I	IN5I	IN6I	IN7I	IN8I	IN9I	IN10	IN11	IN12	
Jacket Assembly													
1	Left Side Panel	60410013	1	1	1	1	1	1	1	1	---	---	---
		60410023	---	---	---	---	---	---	---	---	1	1	1
2	Right Side Panel	60410012	1	1	1	1	1	1	1	1	---	---	---
		60410022	---	---	---	---	---	---	---	---	1	1	1
3	Front Removable Panel	60410033	1	---	---	---	---	---	---	---	---	---	---
		60410043	---	1	---	---	---	---	---	---	---	---	---
		60410053	---	---	1	---	---	---	---	---	---	---	---
		60410063	---	---	---	1	---	---	---	---	---	---	---
		60410073	---	---	---	---	1	---	---	---	---	---	---
		60410083	---	---	---	---	---	1	---	---	---	---	---
		60410093	---	---	---	---	---	---	1	---	---	---	---
		60410103	---	---	---	---	---	---	---	1	---	---	---
		60410113	---	---	---	---	---	---	---	---	1	---	---
4	Vestibule Panel	60410123	---	---	---	---	---	---	---	---	---	---	1
		60410034	1	---	---	---	---	---	---	---	---	---	---
		60410044	---	1	---	---	---	---	---	---	---	---	---
		60410054	---	---	1	---	---	---	---	---	---	---	---
		60410064	---	---	---	1	---	---	---	---	---	---	---
		60410074	---	---	---	---	1	---	---	---	---	---	---
		60410084	---	---	---	---	---	1	---	---	---	---	---
		60410094	---	---	---	---	---	---	1	---	---	---	---
		60410104	---	---	---	---	---	---	---	1	---	---	---
5	Rear Panel IN10, IN11 & IN12 require 5A and 5B (see page 65)	60410114	---	---	---	---	---	---	---	---	---	1	---
		60410124	---	---	---	---	---	---	---	---	---	---	1
		60410035	1	---	---	---	---	---	---	---	---	---	---
		60410045	---	1	---	---	---	---	---	---	---	---	---
		60410055	---	---	1	---	---	---	---	---	---	---	---
		60410065	---	---	---	1	---	---	---	---	---	---	---
		60410075	---	---	---	---	1	---	---	---	---	---	---
		60410085	---	---	---	---	---	1	---	---	---	---	---
		60410095	---	---	---	---	---	---	1	---	---	---	---
5	Rear Panel IN10, IN11 & IN12 require 5A and 5B (see page 65)	60410105	---	---	---	---	---	---	---	1	---	---	
		60410115	---	---	---	---	---	---	---	---	1	---	
		60410125	---	---	---	---	---	---	---	---	---	1	

11 Service Parts *(continued)*

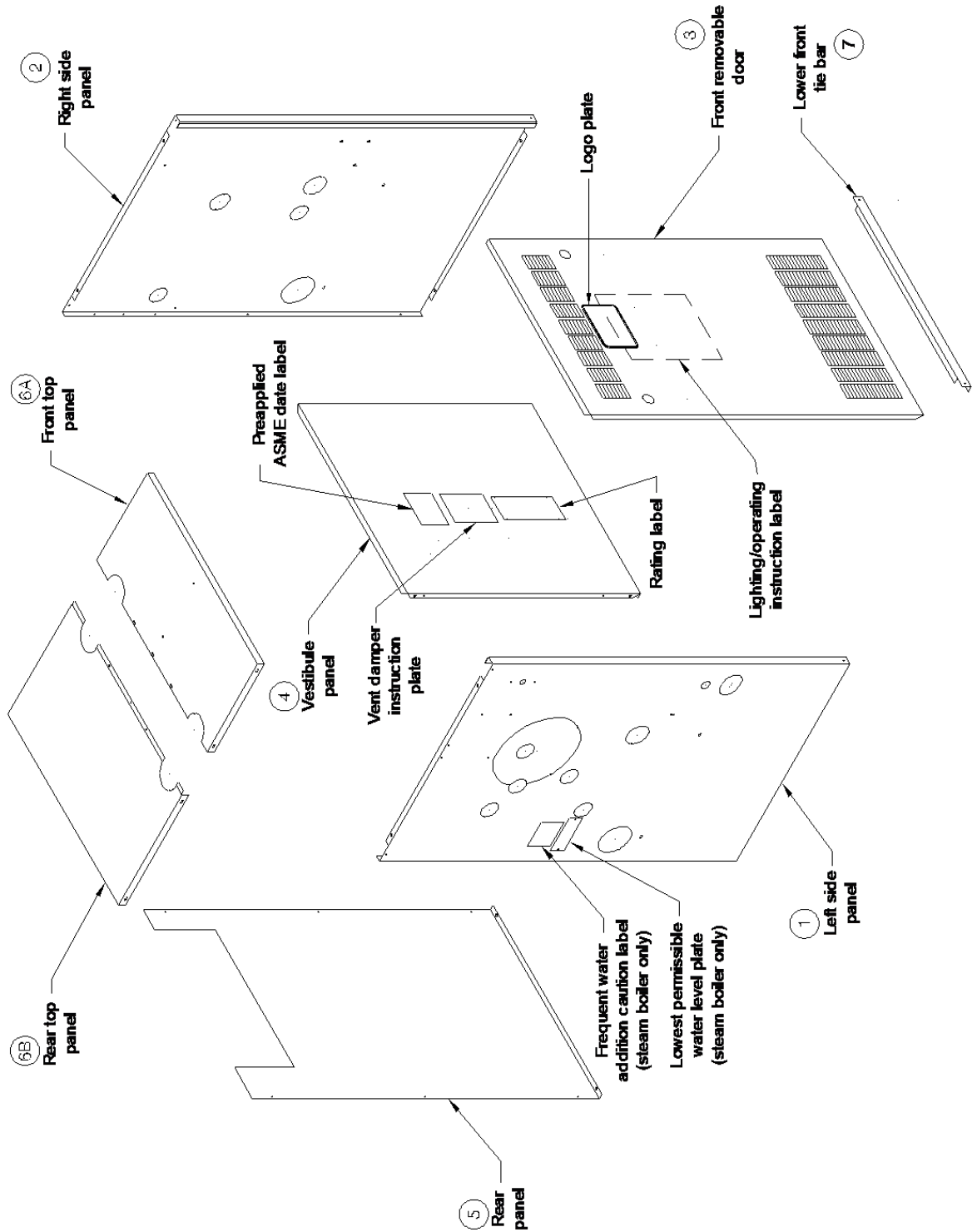

11 Service Parts *(continued)*

Key No.	Description	Part No.	Quantity										
			IN3I	IN4I	IN5I	IN6I	IN7I	IN8I	IN9I	IN10	IN11	IN12	
Jacket Assembly (Continued)													
5A	Upper Left Rear Panel (not shown)	604101051	---	---	---	---	---	---	---	---	1	1	1
5B	Upper Right Rear Panel (not shown)	604101052	---	---	---	---	---	---	---	---	1	1	1
6A	Front Top Panel	60410036	1	---	---	---	---	---	---	---	---	---	---
		60410046	---	1	---	---	---	---	---	---	---	---	---
		60410056	---	---	1	---	---	---	---	---	---	---	---
		60410066	---	---	---	1	---	---	---	---	---	---	---
		60410076	---	---	---	---	1	---	---	---	---	---	---
		60410086	---	---	---	---	---	1	---	---	---	---	---
		60410096	---	---	---	---	---	---	1	---	---	---	---
		60410106	---	---	---	---	---	---	---	---	1	---	---
		60410116	---	---	---	---	---	---	---	---	---	1	---
60410126	---	---	---	---	---	---	---	---	---	---	1		
6B	Rear Top Panel	604100361	1	---	---	---	---	---	---	---	---	---	---
		604100461	---	1	---	---	---	---	---	---	---	---	---
		604100561	---	---	1	---	---	---	---	---	---	---	---
		604100661	---	---	---	1	---	---	---	---	---	---	---
		604100761	---	---	---	---	1	---	---	---	---	---	---
		604100861	---	---	---	---	---	1	---	---	---	---	---
		604100961	---	---	---	---	---	---	1	---	---	---	---
		604101061	---	---	---	---	---	---	---	---	1	---	---
		604101161	---	---	---	---	---	---	---	---	---	1	---
604101261	---	---	---	---	---	---	---	---	---	---	1		
7	Lower Front Tie Bar	70410034	1	---	---	---	---	---	---	---	---	---	---
		70410044	---	1	---	---	---	---	---	---	---	---	---
		70410054	---	---	1	---	---	---	---	---	---	---	---
		70410064	---	---	---	1	---	---	---	---	---	---	---
		70410074	---	---	---	---	1	---	---	---	---	---	---
		70410084	---	---	---	---	---	1	---	---	---	---	---
		70410094	---	---	---	---	---	---	1	---	---	---	---
		70410104	---	---	---	---	---	---	---	---	1	---	---
		70410114	---	---	---	---	---	---	---	---	---	1	---
70410124	---	---	---	---	---	---	---	---	---	---	1		

11 Service Parts *(continued)*

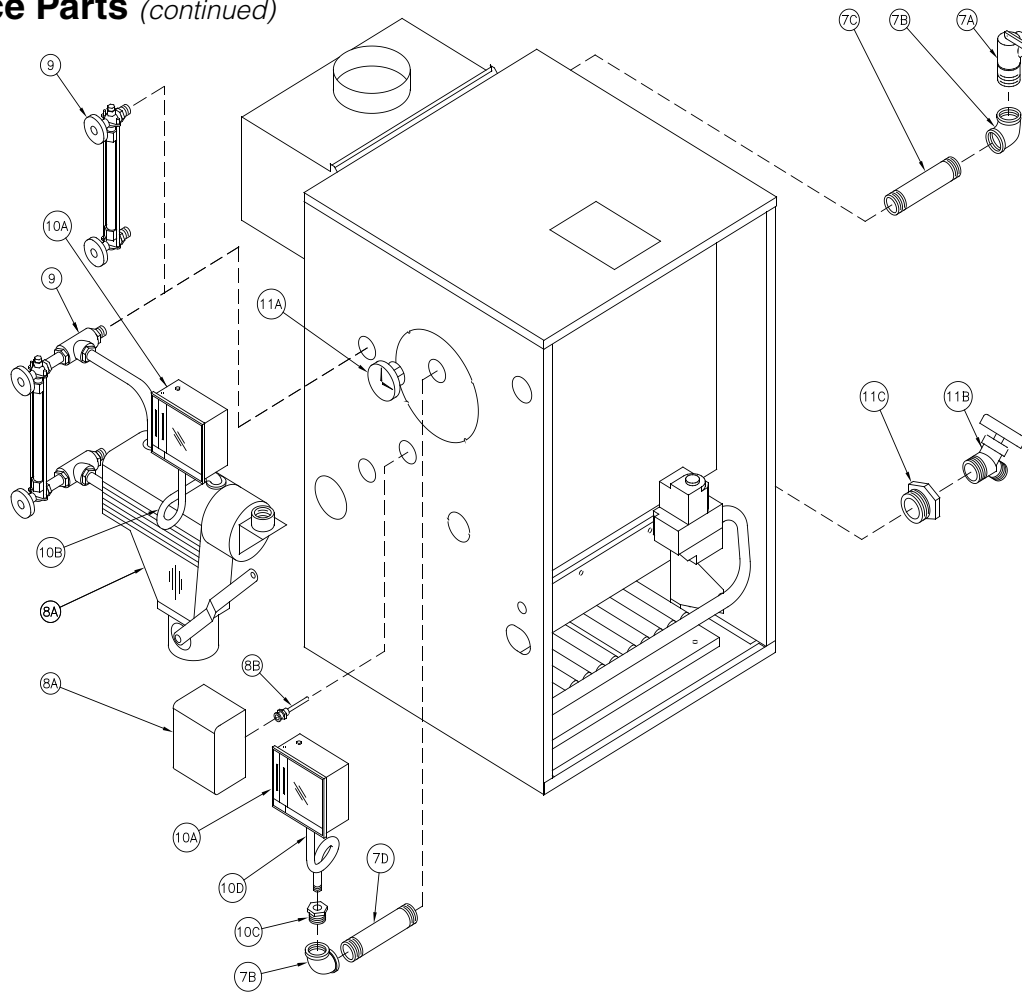

Key No.	Description	Part No.	Quantity
Steam Trim			
7A	Safety Valve, 3/4 NPT, 15 psi, Conbraco 13-511-08	81660530	1
7B	Elbow, 3/4 NPT	806601502	2
7C	Nipple, 3/4 NPT x 3-1/2"	806600038	1
7D	Nipple, 3/4 NPT x 4"	806600014	1
8A	Low Water Cutoff, McDonnell & Miller PSE-802-24 (Probe Included)	104206-01	1
	Low Water Cutoff, Hydrolevel CG400-2090 (Less Probe - See Key No. 8B)	80160725	
	Low Water Cutoff, McDonnell & Miller 67-BC-1 (Float Type)	80160517	
8B	Probe for CG400	80160629	1
9	Gauge Glass, Extended Shank (with Probe LWCO Only)	8056128	1
	Gauge Glass, Standard Shank (with Float LWCO Only)	8056020	
10A	Limit, Honeywell L404F1367	80160369	1
10B	Syphon, 1/4 NPT x 90°	806603039	1
10C	Bushing, 3/4 NPT x 1/4 NPT	806604655	1
10D	Syphon, 1/4 NPT x 180°	106333-01	1
11A	Pressure Gauge	100325-01	1
11B	Drain Valve, Conbraco 31-612-02	806603012	1
11C	Bushing, 2 NPT x 3/4 NPT	806600515	1

11 Service Parts *(continued)*

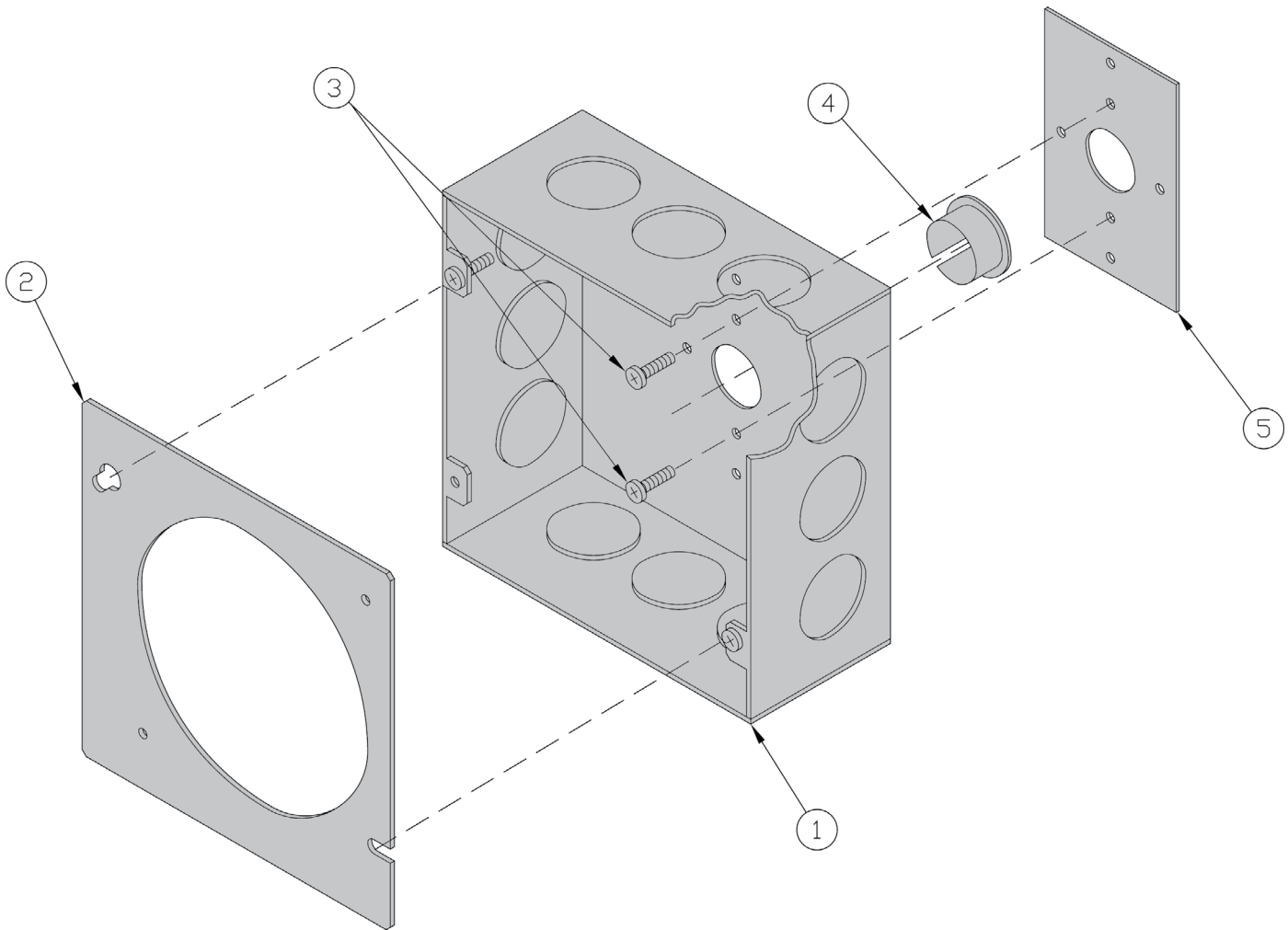

Key No.	Description	Part No.	Quantity									
			IN3I	IN4I	IN5I	IN6I	IN7I	IN8I	IN9I	IN10	IN11	IN12
Transformer/J-Box Adapter Plate												
1	Junction Box, 4-11/16" x 4-11/16" x 2-1/8"	81361761	1	1	1	1	1	1	1	1	1	1
2	Transformer/J-Box Adapter Plate	7011001	1	1	1	1	1	1	1	1	1	1
3	Sheet Metal Screw, #8 x 1/2, Type B, Phillips Head, Blunt	80860019	2	2	2	2	2	2	2	2	2	2
4	O/CL Bushing, Heyco OCB-875	8136066	1	1	1	1	1	1	1	1	1	1
5	J-Box Attachment Bracket	7131001	1	1	1	1	1	1	1	1	1	1

11 Service Parts *(continued)*

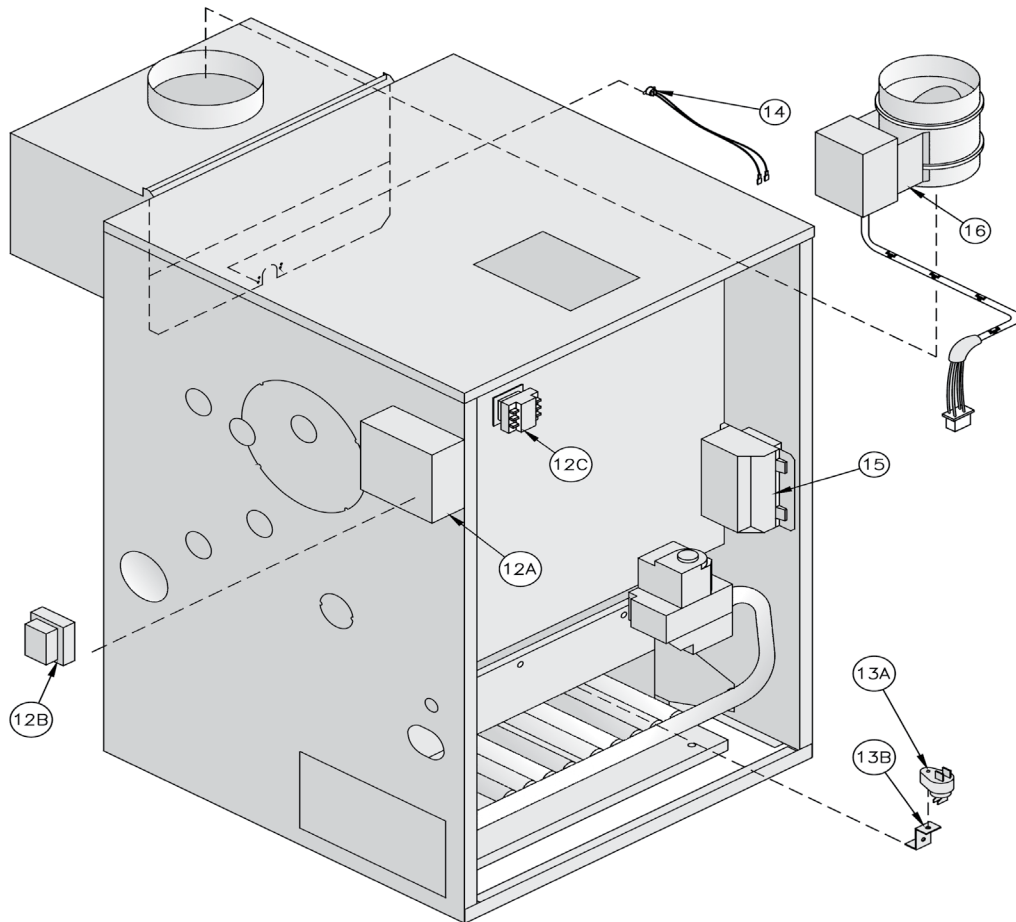

Key No.	Description	Part No.	Quantity										
			IN3I	IN4I	IN5I	IN6I	IN7I	IN8I	IN9I	IN10	IN11	IN12	
12. Transformer													
12A	Junction Box, 4-11/16" x 4-11/16" x 2-1/8"	Refer to Table on Page 67											
12B	Transformer, 50 VA, Honeywell AT150D1019	80160186	1	1	1	1	1	1	1	1	1	1	1
12C	Relay, SPST, Honeywell R8222K1000	80160127	1	1	1	1	1	1	1	1	1	1	1
13. Flame Rollout Switch													
13A	Flame Rollout Switch	80160044	1	1	1	1	1	1	1	1	1	1	1
13B	Flame Rollout Switch Bracket	7186018	1	1	1	1	1	1	1	1	1	1	1
14. Blocked Vent Switch													
14	Blocked Vent Switch	6016067	1	1	1	1	1	1	1	---	---	---	
		6111001	---	---	---	---	---	---	---	1	1	1	
15. Ignition Module (Intermittent Ignition Only)													
15	Ignition Module, Honeywell S8610M3009	100958-01	1	1	1	1	1	1	1	1	1	1	1
---	Ignition Module Support Bracket	7016001	1	1	1	1	1	1	1	1	1	1	1
16. Vent Damper													
16	4"	8116321	1	---	---	---	---	---	---	---	---	---	---
	5"	8116322	---	1	---	---	---	---	---	---	---	---	---
	6"	8116323	---	---	1	1	---	---	---	---	---	---	---
	7"	8116324	---	---	---	---	1	1	---	---	---	---	---
	8"	8116325	---	---	---	---	---	---	1	1	---	---	---
	9"	8116326	---	---	---	---	---	---	---	---	1	1	

U.S. Boiler Company, Inc.
P.O. Box 3020
Lancaster, PA 17604
1-888-432-8887
www.usboiler.net